

# Amphenol SV MICROWAVE

**R**efortless

---



# BLINDMATE CONNECTORS AND COMPONENTS

SV Microwave, Inc. is a world leader in the RF/microwave industry. We design and manufacture coaxial connectors, cable assemblies, attenuators, terminations, and custom signal processing components. We control virtually all of our processes with in-house machining, fabrication, assembly and testing.

SV Microwave is committed to helping customers meet their RF and microwave performance goals. We have invested in a talented engineering staff supported by state-of-the-art design, high-frequency software for 3-dimensional RF simulations and network measurement test equipment, and can provide detailed design assistance for unique applications from DC through millimeter wave frequencies.

SV Microwave supplies products that are electrically and mechanically optimized. We meet cost requirements either by customizing connectors and components for new applications, by supplying products discontinued by other manufacturers or by manufacturing high-volume components.

SV Microwave is a global leader in the development and application of Blindmate connector technology and has been spearheading the use of these connectors in advanced packaging concepts for the defense and telecommunication industries. We are the only manufacturer to obtain DSCC M31031 QPL status.

## Selection Guide

Specification	Blindmate Interface			
	BMA	BMMA	BMZ	BZ
Frequency	DC - 22 GHz*	DC - 28 GHz	DC - 18 GHz	DC - 2 GHz**
VSWR (f = Frequency GHz)	1.02 + .008f	1.05 + .01f	1.05 + .01f	1.02 + .05f
Insertion Loss (f = GHz)	.03(f) <sup>1/2</sup>	.04(f) <sup>1/2</sup>	.06(f) <sup>1/2</sup>	.15(f) <sup>1/2</sup>
RF Leakage Min.	-(90-fGHz) dB	-(90-fGHz) dB	-(80-fGHz) dB	-(80-fGHz) dB
RF High Potential @ 5 MHz	1,000 VRMS	675 VRMS	500 VRMS	1,500 VRMS
Radial Float inches (mm)	.020 (.51)	.020 (.51)	.020 (.51)	.020 (.51)
Axial Float inches (mm)	.060 (1.5)	.060 (1.5)	.060 (1.5)	.150 (3.8)
Connector Durability	5,000 Cycles	1,000 Cycles	500 Cycles	500 Cycles
Spring Load: Preload – Minimum Travel	.010 inch (.25 mm)	.010 inch (.25 mm)	.004 inch (.10 mm)	.010 inch (.25 mm)
Preload Force	3.7 lbs. (1.68 kg)	3.7 lbs. (1.68 kg)	1.28 lbs. min. (.5 kg min)	3 lbs. (1.36 kg)
Max. Travel Force	4.5 lbs. (2.04 kg)	4.5 lbs. (2.04 kg)	2.8 lbs. (1.27 kg)	.150 in. travel/ 5 lbs. ( 3.81 mm travel/ 2.27 kg))
Force to Engage	48 oz. Max. (1361 g)	48 oz. Max. (1361 g)	12 oz. Max. (340 g)	32 oz. Max. (907 g)
Force to Disengage	1.5 lbs. Max. (.675 kg)	1.5 lbs. Max. (.675 kg)	2 oz. Min. (57 g)	2 oz. Min. (57 g)

\* 26.5 GHz available for semi-rigid cable and receptacles.

\*\* 12.4 and 18 GHz units available.

## Contents

---

<b>Section / Product</b> . . . . .	<b>Page</b>
<b>Applications</b> . . . . .	<b>1</b>
<b>BMA</b> . . . . .	<b>6</b>
Interface Mating Dimensions . . . . .	6
Specifications . . . . .	7
Semi-Rigid Cable Connectors . . . . .	8
Flexible Cable Connectors . . . . .	9
Panel Mount Connectors . . . . .	10
Terminations . . . . .	12
Between-Series Adapters . . . . .	12
Tools . . . . .	12
<b>BMMA</b> . . . . .	<b>13</b>
Interface Mating Dimensions . . . . .	13
Specifications . . . . .	14
Semi-Rigid Cable Connectors . . . . .	15
Between-Series Adapters . . . . .	16
Tools . . . . .	16
<b>BMZ</b> . . . . .	<b>17</b>
Interface Mating Dimensions . . . . .	17
Specifications . . . . .	18
Semi-Rigid Cable Connectors . . . . .	19
Flexible Cable Connectors . . . . .	20
Panel Mount Connectors . . . . .	21
Between-Series Adapters . . . . .	22
Tools . . . . .	22
<b>BZ</b> . . . . .	<b>23</b>
Interface Mating Dimensions . . . . .	23
Specifications . . . . .	24
Semi-Rigid Cable Connectors . . . . .	25
Terminations . . . . .	26
Between-Series Adapters . . . . .	26
Tools . . . . .	26
<b>Appendix A – Recommended Mounting Hole Details</b> . . . . .	<b>27</b>
<b>Part Number Index</b> . . . . .	<b>29</b>

# BLINDMATE CONNECTOR SYSTEM

## Applied Technology

Blindmate connectors are often the solution when mating modular components in rack-and-panel, module-to-module or module-to-motherboard applications. Identifying the appropriate connector for the job is as crucial as pinpointing mounting features such as:

- Fixed and float tolerances, connector-to-connector
- Float mount spring loading and mating forces
- Density of connectors in multi-connector arrays
- Panel deflection

Blindmate connectors are ideally suited for OEMs who need modularity to integrate subsystems and components such as power amplifiers, transceivers and combiners into common racks in wireless/broadcast and communications systems. Blindmate connectors are also commonly found in satellites, radar and sensor equipment, avionics, missile systems, military electronics, electronic countermeasure systems, navigation and air traffic control, as well as automated test equipment.

To adapt to this wide assortment of applications, SV Microwave blindmate connectors are configured in various ways:

- Fixed, floating, high-power and hermetic versions
- Flexible and semi-rigid cable connectors
- Low-profile styles
- Stripline and microstrip launchers
- Hermetic launchers
- Between-series adapters
- Terminations

Our blindmates also offer efficiencies in the areas of higher package densities, effective real estate and lower applied cost. They connect and disconnect quickly and offer slide-on mating without sacrificing superior microwave performance. Our unique spring-loading mechanism allows for both axial and radial misalignment.

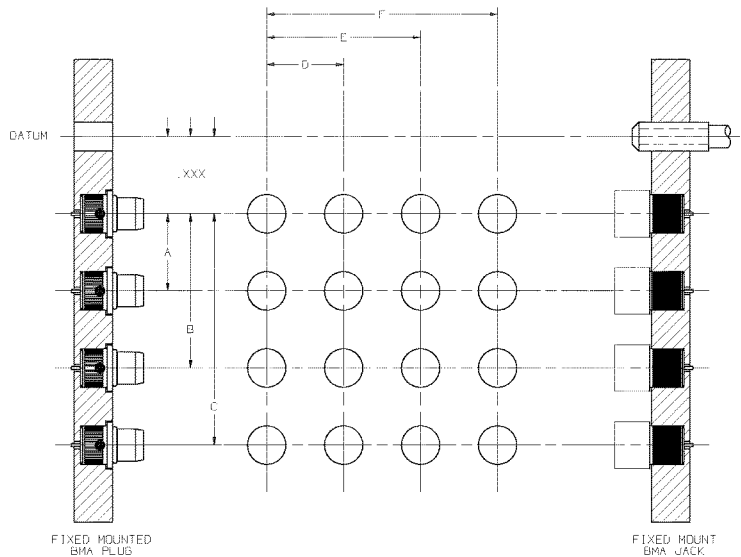

Fixed-Mount Blindmate

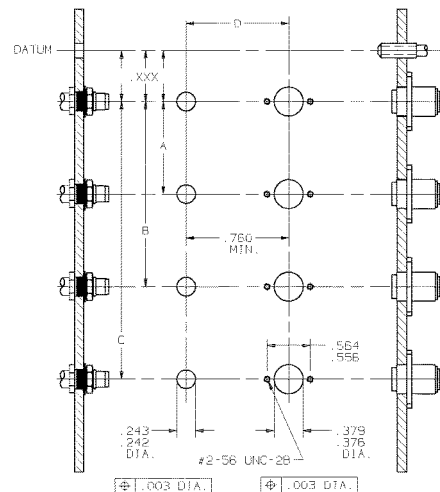

Float-Mount Blindmate

# BLINDMATE CONNECTOR SYSTEM

## Module-Module and Module-Motherboard Misalignment Tolerances: Fixed Mount

When using fixed mount blindmate connectors, axial and radial float tolerances of the interface accommodate misalignment.

Fixed mount blindmate connectors also tolerate a certain degree of radial misalignment without electrical or mechanical performance degradation.

Axial Misalignment

Interface	Maximum Separation	Design Limit
BMA	.030 in. (.76 mm)	.015 in. (.38 mm)
BMMA	.020 in. (.51 mm)	.010 in. (.25 mm)
BMZ	.020 in. (.51 mm)	.010 in. (.25 mm)
BZ	.030 in. (.76 mm)	.015 in. (.38 mm)

Radial Misalignment

Interface	True Position Mounting Hole Centerline Tolerance	Total Connector Misalignment*
BMA	.003 in. (.08 mm)	.008 in. (.20 mm)
BMMA	.002 in. (.05 mm)	.004 in. (.10 mm)
BMZ	.002 in. (.05 mm)	.004 in. (.10 mm)
BZ	.003 in. (.08 mm)	.008 in. (.20 mm)

\*per mated pair, any direction

## Rack-and-Panel and Module-Motherboard Misalignment Tolerances: Float Mount

Blindmate float mount jack connectors are ideal for applications, such as multiple mate rack-and-panel, requiring higher axial and radial misalignment tolerances. The external float device provides connection protection beyond the normal blindmate interface misalignment tolerance

### Axial Misalignment

Assuming a 0.010-inch min. preload, the float mount design accommodates up to a .050-inch longitudinal misalignment (mounting surface to mounting surface). If semi-rigid cable is needed, a service loop should be used to fully enable the connector's float features.

### Radial Misalignment

Our floating connectors accommodate  $\pm .020$  radial misalignment with a mounting hole centerline dimensioned from a predesignated datum of  $\text{Ⓢ} \text{.006 Dia.}$ . The radial tolerance accommodates mating package misalignment and mounting hole tolerance.

## Recommended Preload

Interface	Recommend Preload
BMA	.010 in (.25 mm)
BMMA	.010 in (.25 mm)
BMZ	.004 in (.10 mm)
BZ	.010 in (.25 mm)



# BLINDMATE CONNECTOR SYSTEM

## Spring Load Forces

A spring mechanism separates the blindmate connector interface from the flange housing. The floating action that results provides the misalignment tolerance and maintains a solid mating connection. Bear in mind that the spring forces are communicated to the mounting panel; in an extreme, mismatch situation, the force of several connectors, without sufficient reinforcement, can cause panels to bow. Illustrated below are the forces commonly exerted upon a mated connector pair in an extreme scenario.

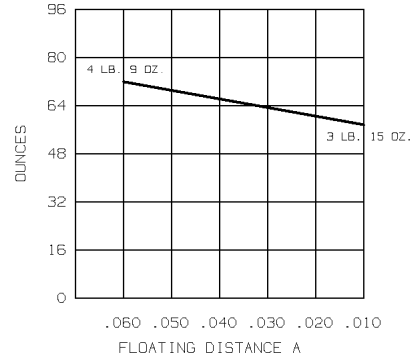
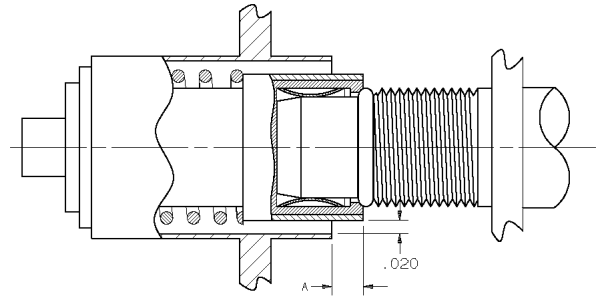

**BMA Spring Load Forces**

Note: Dimensions are in decimal inches.

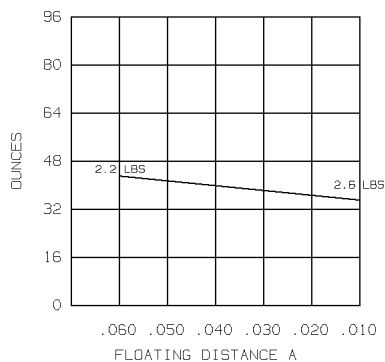
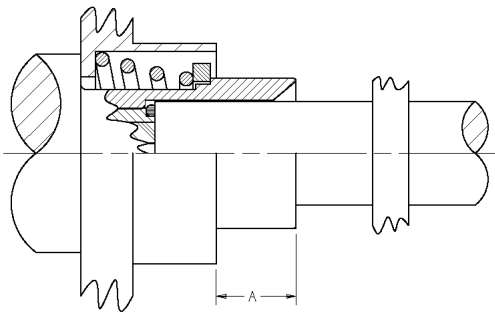

**BMZ Spring Load Forces**

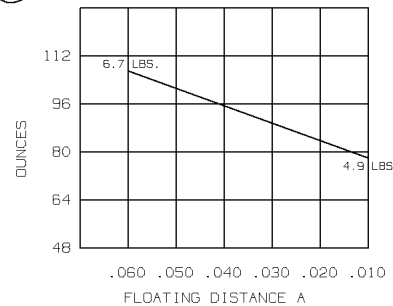
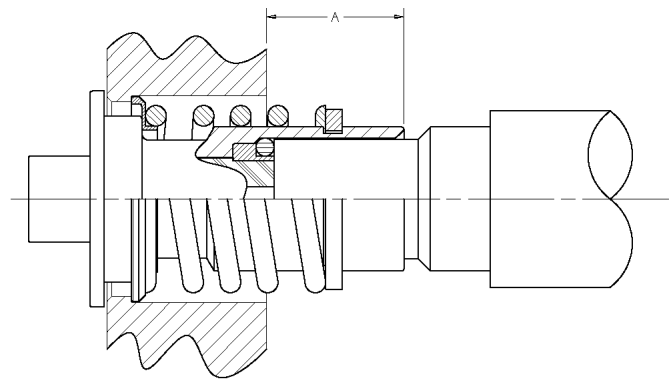

**BZ Spring Load Forces**

# BLINDMATE CONNECTOR SYSTEM

## Deflection Calculation

Interface mating forces and, in the case of float mount connectors, spring preload forces must be considered when mounting several blindmate connectors on a panel. Taking these forces into account in the design stage will prevent distortion (deflection) of the panel and, through proper mating, insure optimum performance. One technique used to estimate the amount of potential distortion is to view the panel as a beam under deflection. These examples illustrate this technique using 6 BMA float mount connectors on an aluminum and a stainless steel panel.

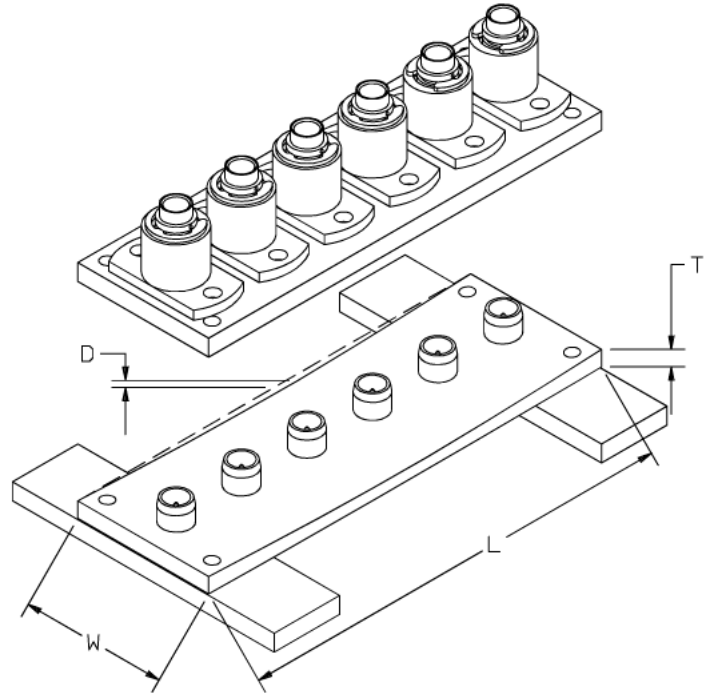

$$\text{Deflection: } D = \frac{FL^3}{384 EI}$$

$$\text{Moment of a Beam: } I = \frac{WT^3}{12}$$

Material: 6061T6 Aluminum

Modulus of Elasticity:  $E = 10 \times 10^6$  PSI

Float Mount Connector Example:

- 6 float mount BMAs with a maximum compression load of 4 lbs. 8 oz. each ( $F = 27$  lbs.)
- Aluminum mounting plate 6061T6  
.090 inch thick ( $T$ ) x .750 inch wide ( $W$ ) x 2.00 inch long ( $L$ )

$$I = 4.56 \times 10^{-5} \text{ inch}^4$$

$$D = \frac{(27)(2.00)^3}{(384)(10 \times 10^6)(4.56 \times 10^{-5})} = .00123 \text{ inch}$$

Material: Stainless Steel 18-8

Modulus of Elasticity:  $E = 27.6 \times 10^6$  PSI

$$D = .00045 \text{ inch}$$

## Interface Mating Dimensions

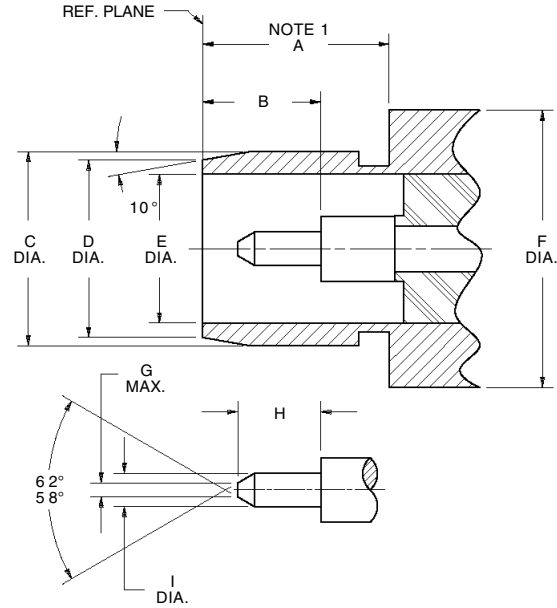
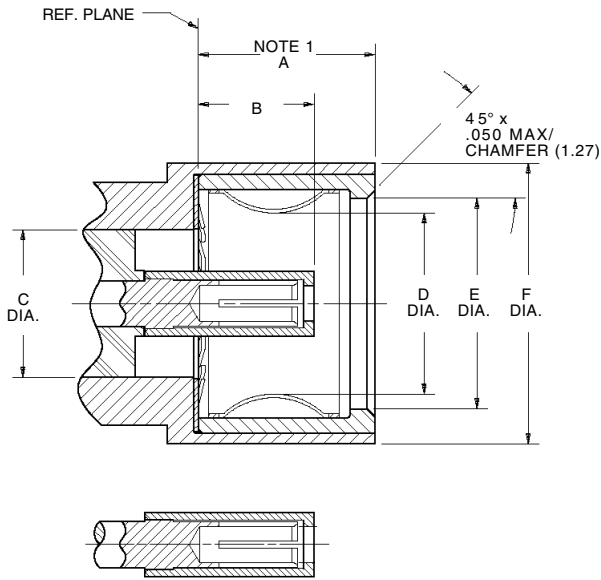

CLOSED TO MEET VSWR, MATING CHARACTERISTICS AND CONNECTOR DURABILITY WHEN MATED WITH APPROPRIATE MALE CONTACT.

### Jack

Letter	Inches (Millimeters)
A	.195 Max. (5.03)
B	.127 Max. (3.23)
C	.161 Nom. (4.09)
D	.200 Max. (5.08)
E	.225 Min. (5.72)
F	.290 Min. (7.37)

NOTES:  
1. With spring finger bottomed.

### Plug

Letter	Inches (Millimeters)
A	.198 Min. (5.03)
B	.128 Min. (3.25)
C	.211 Max. (5.36)
D	.192 Nom. (4.88)
E	.161 Nom. (4.09)
F	.300 Nom. (7.62)
G	.015 Max. (0.38)
H	.090 Nom. (2.29)
I	.037 Max. (.94)

NOTES:  
1. Clearance for mating connector coupling nut.

Dimensions are in inches.  
Metric equivalents are given for general information only.



## Specifications

### General

Materials	Body, Stainless steel per AMS-5640, UNS S30300, Type I. Brass is also available. Contact, Beryllium copper per ASTM-B-196. PTFE per ASTM-D-1710
Finish	Body, Gold plated per ASTM-B-488 over nickel per SAE AMS-QQ-N-290, Class 1 or passivate. Center Contact, Gold plated per ASTM-B-488 over nickel per SAE AMS-QQ-N-290, Class 1
Design	Interface dimensions per MIL-STD-348.

### Electrical

	<b>RG 402 (.141) Semi-Rigid</b>	<b>RG 405 (.085) Semi-Rigid</b>
Frequency	DC to 22 GHz (DC to 26.5 GHz available for semi-rigid cable and receptacles)	DC to 22 GHz
Nominal Impedance	50 Ohms	50 Ohms
VSWR		
DC to 18 GHz	1.02 + .005f (GHz)	1.05 + .005f (GHz)
18 to 22 GHz	1.02 + .008f (GHz)	1.05 + .009f (GHz)
RF Transmission Loss	.03x√f (GHz)	.03x√f (GHz)
Insulation Resistance	5,000 Megohms Min.	5,000 Megohms Min.
Contact Resistance		
Center Contact	2.0 Milliohms Max.	2.0 Milliohms Max.
Outer Contact	2.0 Milliohms Max.	2.0 Milliohms Max.
Dielectric Withstanding Voltage	1500 Volts RMS	1000 Volts RMS
Corona Extinction Voltage at 70,000 Ft.	375 Volts Min.	335 Volts Min.
RF High Potential at 5 MHz	1,000 Volts RMS	670 Volts RMS
RF Leakage	-(90-fGHz) dB Min.	-(90-fGHz) dB min.
Interface Only	(fully mated)	(fully mated)

### Mechanical

Force to Engage	48 Ounces Max.
Force to Disengage	1.5 Pounds Max.
Center Contact Retention	6 Pounds Min.
Durability	5,000 Cycles
Radial Misalignment	
Rigid Mount	± .004 Inch
Float Mount	± .020 Inch

### Environmental

Temperature Rating	-65°C to +125°C (Semi-Rigid)
Corrosion (Salt Spray)	MIL-STD-202, Method 101, Condition B
Vibration	MIL-STD-202, Method 204, Condition D, 20 Gs
Shock	MIL-STD-202, Method 213, Condition I, 100 Gs
Thermal Shock	MIL-STD-202, Method 107, Condition B, -65°C to +125°C
Moisture Resistance	MIL-STD-202, Method 106, Less Step 7B
Barometric Pressure (Altitude)	MIL-STD-202, Method 105, Condition C, 70,000 Ft.

# BMA BLINDMATE CONNECTORS DC to 22 GHz

## Semi-Rigid Cable • Direct Solder Attachment

### Low Profile • Panel Feedthrough Cable Jack Floating Rear Mount

Cable	RG-405/U (.085)	RG-402/U (.141)
Part Number	<b>1740-6001</b>	<b>1742-6002</b>
Dim. A	Inches (mm) .120 (3.05)	Inches (mm) .180 (4.57)
Dim. B	.089 Min. (2.26)	.144 Min. (3.66)
Dim. C	.580 (14.73)	.580 (14.73)

Finish: Housing that is soldered to cable outer conductor is gold plated.  
Refer to Recommended Mounting Hole Detail E in Appendix A.  
NOTE 1: With .060 Min. (1.52) axial float.

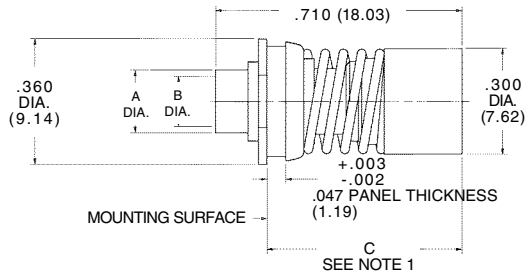

### Flange Mount Cable Jack Floating Rear Mount

Cable	RG-405/U (.085)	RG-402/U (.141)
Commercial Part No.	<b>SF1733-6006</b>	<b>SF1732-6004</b>
MIL Part Number	<b>M31031/11-E5N02</b>	<b>M31031/11-E5N01</b>
Dim. A	Inches (mm) .120 (3.05)	Inches (mm) .180 (4.57)
Dim. B	.089 Min. (2.26)	.144 Min. (3.66)

Flange shroud will rotate a full 360° for optimum adjustment prior to mounting.  
Finish: Inner housing that is soldered to cable is gold plated. Outer housing is passivated stainless steel.  
Refer to Recommended Mounting Hole Detail A in Appendix A.  
A semi-rigid cable service loop is recommended.

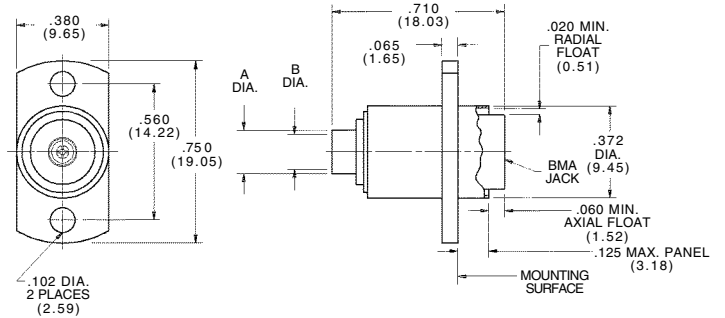

### Bulkhead Feedthrough Cable Jack Rear Mount

Cable	RG-405/U (.085)
Part Number	<b>1733-6008</b>

Finish: Gold plated.  
Refer to Recommended Mounting Hole Detail O in Appendix A.

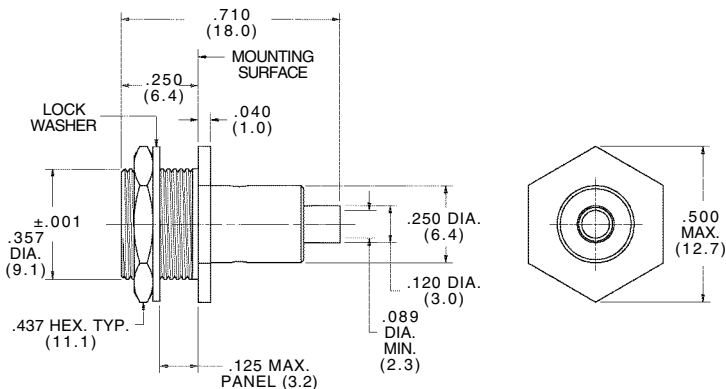

### Bulkhead Feedthrough Cable Plug Rear Mount

Cable	RG-405/U (.085)	RG-402/U (.141)
Commercial Part No.	<b>1708-6003</b>	<b>1709-6002</b>
MIL Part Number	<b>M31031/12-E5N02</b>	<b>M31031/12-E5N01</b>
Brass Body Part No.	<b>1708-0001</b>	—
Dim. A	Inches (mm) .120 (3.05)	Inches (mm) .180 (4.57)
Dim. B	.089 Min. (2.26)	.144 Min. (3.66)

Finish: Gold plated.  
Refer to Recommended Mounting Hole Detail C in Appendix A.

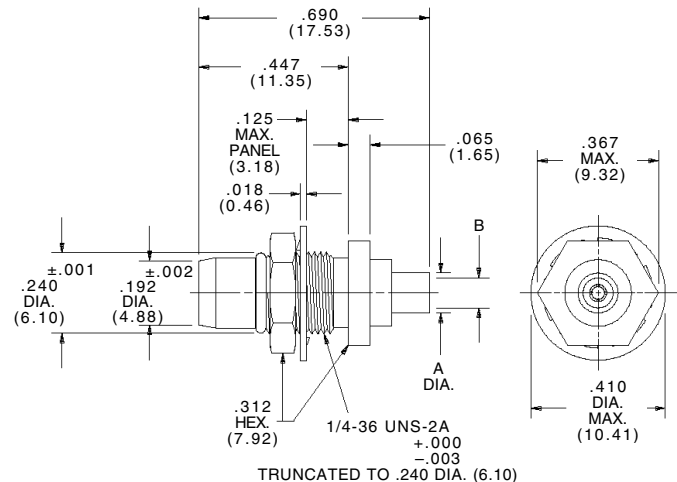

# BMA BLINDMATE CONNECTORS DC to 22 GHz

## Flexible Cable • Crimp Attachment

### Low Profile • Panel Feedthrough Cable Jack Floating Rear Mount • DC to 12.4 GHz

Cable	RG-316
Part Number	<b>SF1721-6002</b>

Finish: Passivated stainless steel.  
See Recommended Mounting Hole Detail E in Appendix A.  
NOTE 1: With .060 Min. (1.52) axial float.

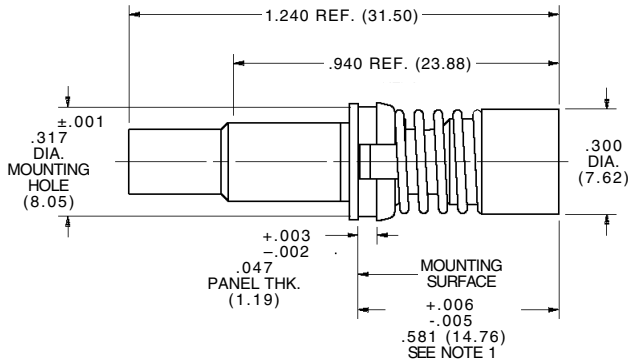

### Flange Mount Cable Jack • Floating Rear Mount DC to 12.4 GHz

Cable	RG-400	RG-316
Commercial Part No.	<b>SF1738-6001</b>	<b>SF1738-6002</b>
MIL Part Number	<b>M31031/01-A5N02</b>	<b>M31031/01-A5N01</b>

Flange shroud will rotate a full 360° for optimum adjustment prior to mounting.  
Finish: Passivated stainless steel.  
See Recommended Mounting Hole Detail A in Appendix A.

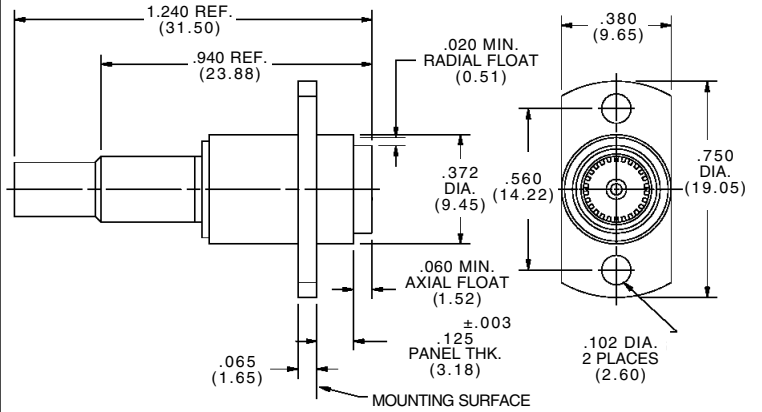

### Bulkhead Feedthrough Cable Plug Rear Mount • DC to 12.4 GHz

Cable	RG-400	RG-316
Commercial Part No.	<b>SF1708-6301</b>	<b>SF1708-6302</b>
MIL Part Number	<b>M31031/02-E5N02</b>	<b>M31031/02-E5N01</b>

Finish: Passivated stainless steel.  
See Recommended Mounting Hole Detail C in Appendix A.

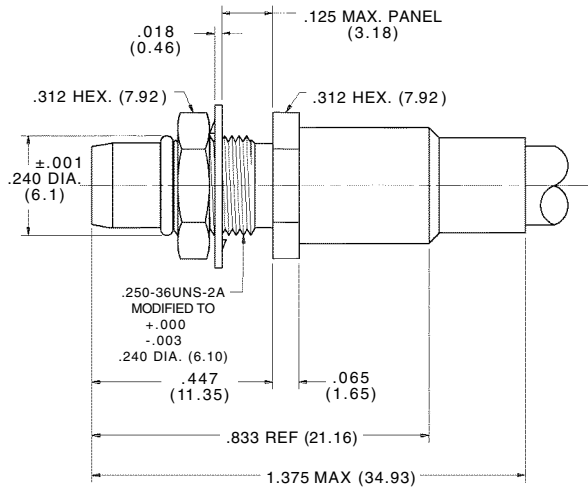

## Flexible Cable • Solder Attachment

### Low Profile • Panel Feedthrough Right Angle Cable Jack • Floating Rear Mount DC to 12.4 GHz

Cable	RG-316
Part Number	<b>SF1769-6501</b>

Finish: Gold plate.  
See Recommended Mounting Hole Detail P in Appendix A.

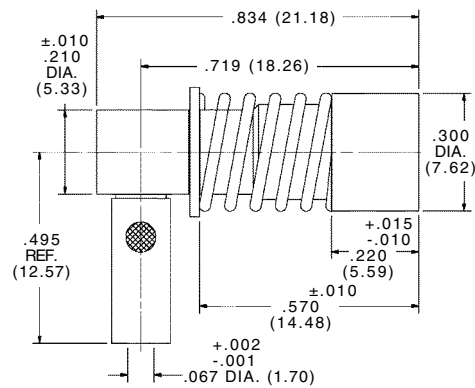

## Panel Mount • Straight Terminal

### Flange Mount Jack Receptacle

Part Number	<b>SF1750-6101</b>
-------------	--------------------

Finish: Passivated stainless steel.  
See Recommended Mounting Hole Detail J in Appendix A.

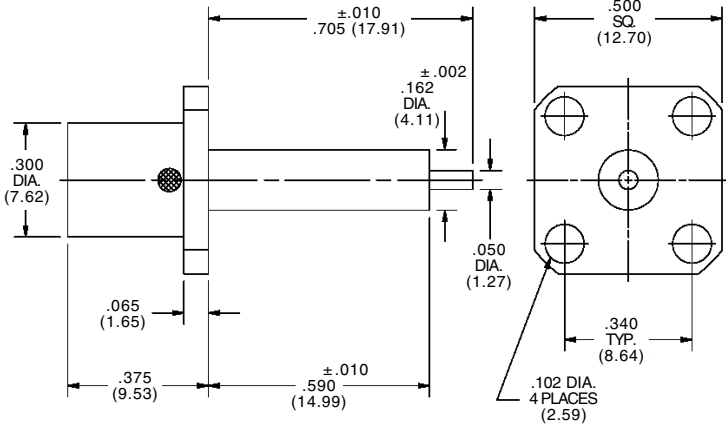

### Flange Mount Plug Receptacle

Part Number	<b>SF1755-6104</b>		<b>SF1755-6105</b>	
Dim. A	Inches	(mm)	Inches	(mm)
Dim. A	.488	(12.40)	.375	(9.53)
Dim. B	.330	(8.38)	.250	(6.35)

Finish: Passivated stainless steel.  
See Recommended Mounting Hole Detail J in Appendix A.

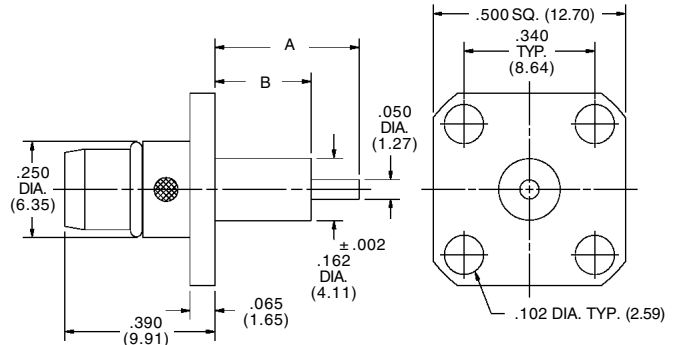

### Press-In Receptacles

Jack Part Number	<b>SF1772-6005</b>
Plug Part Number	<b>SF1774-6001</b>

Finish: Passivated stainless steel. For jack, see Recommended Mounting Hole K in Appendix A. For plug, see Recommended Mounting Hole D in Appendix A.

#### Jack

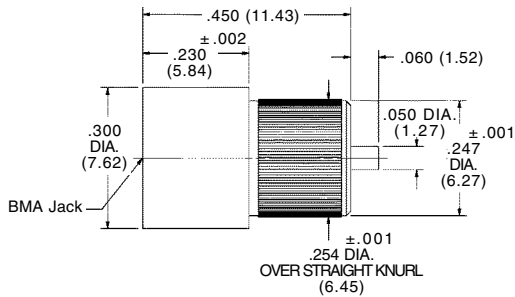

#### Plug

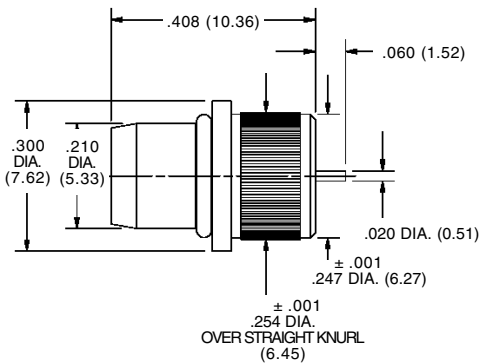

### Straight Plug Receptacle Printed Circuit Board

Part Number	<b>1785-6001</b>
-------------	------------------

Finish: Gold plate.  
See Recommended Mounting Hole L in Appendix A.

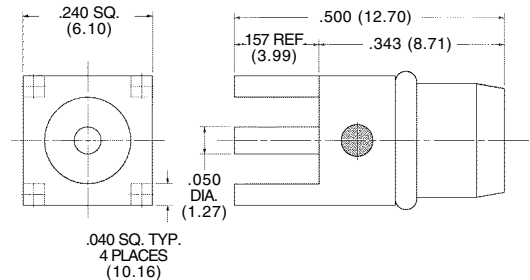

## Panel Mount • Straight Terminal

### Right Angle Plug Receptacle Printed Circuit Board

Part Number **1789-6001**

Finish: Gold plate.  
See Recommended Mounting Hole Detail L in  
Appendix A.

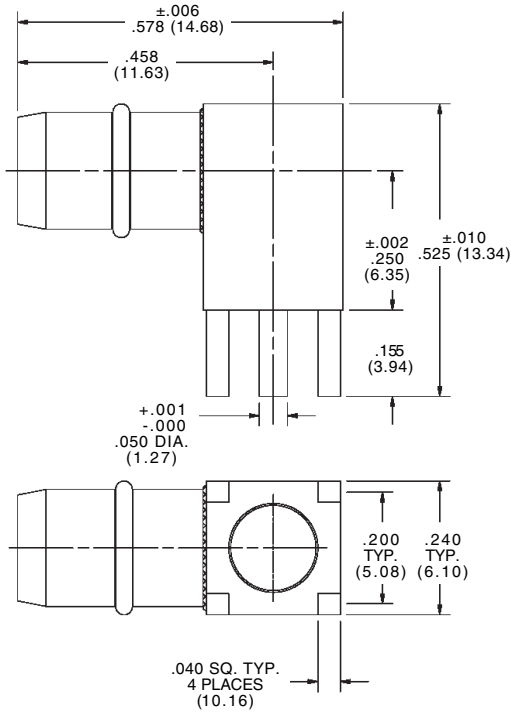

## Metal-to-Metal Hermetic Seal

### Rigid Gasket Seal Panel Feedthrough Jack Receptacle

Part Number **SF1778-6000**

Finish: Passivated stainless steel.  
See Recommended Mounting Hole Detail M in  
Appendix A.

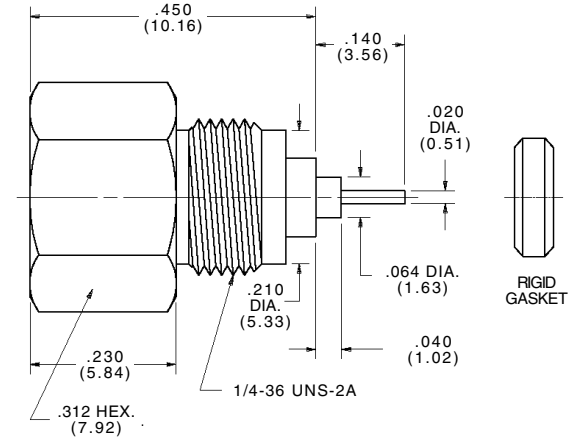

## Panel Mount • End Launch

### Jack Receptacle • Printed Circuit Board

Part Number **1785-0003**

Finish: Tri-metal (copper, tin, zinc) plated brass body.

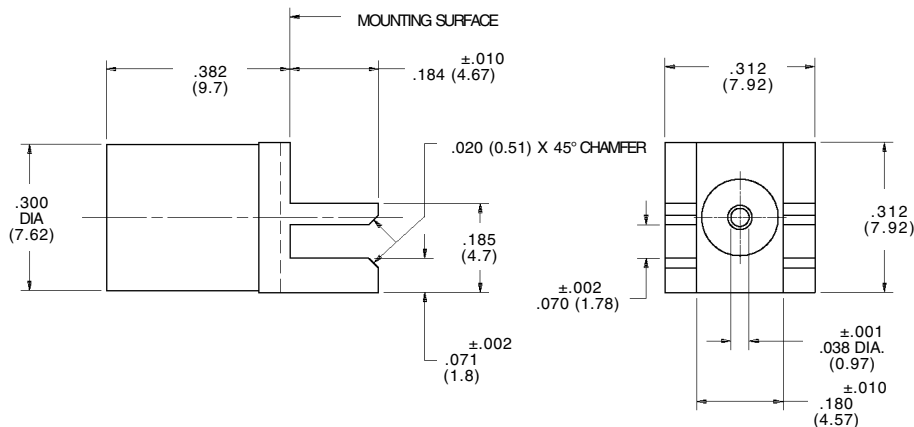

## Flange Mount Plug Termination DC – 18 GHz

Part Number	<b>SF8017-6001</b>
Power Avg. (Watts)	1.0*

Finish: Passivated stainless steel.  
See Recommended Mounting Hole Detail J in Appendix A.  
\*Power derated linearly to 10% power at 125°C.

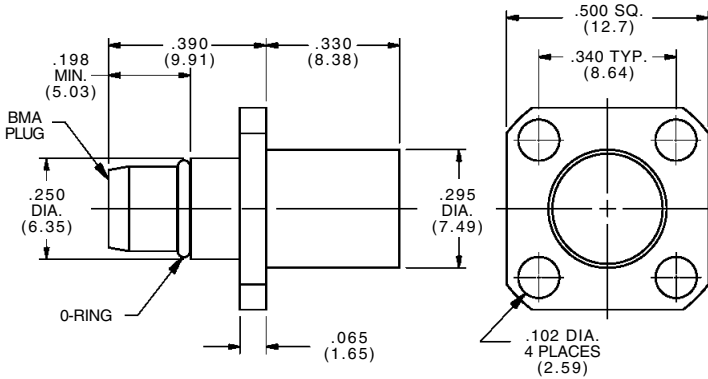

## Float Mount Jack Termination DC – 12 GHz

Part Number	<b>8017-6002</b>
Power Avg. (Watts)	1.0*

Finish: Gold plate.  
See Recommended Mounting Hole Detail E in Appendix A.  
\*Power derated linearly to 10% power at 125°C  
NOTE 1: With .060 Min. (1.52) axial float..

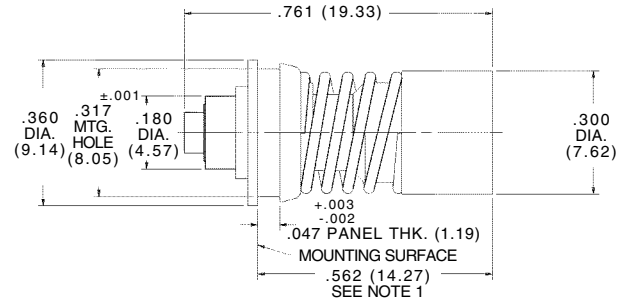

## BMA Removal Tool

Part Number	<b>500-17-000</b>
-------------	-------------------

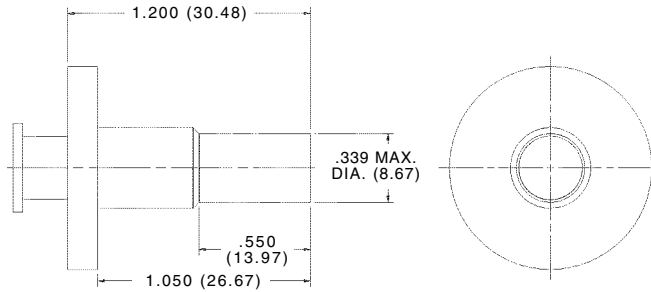

## Between-Series Adapters

Description	Part Number
SMA Jack to BMA Jack	<b>SF1157-6009</b>
SMA Plug to BMA Jack	<b>SF1157-6013</b>
SMA Plug to BMA Plug	<b>SF1157-6010</b>
SMA Jack to BMA Plug	<b>SF1158-6001</b>
3.5mm Jack to BMA Jack	<b>1139-6004</b>
3.5mm Jack to BMA Plug	<b>1139-6005</b>

Finish: BMA to SMA are passivated stainless steel.  
BMA to 3.5mm are gold plate.



## Interface Mating Dimensions

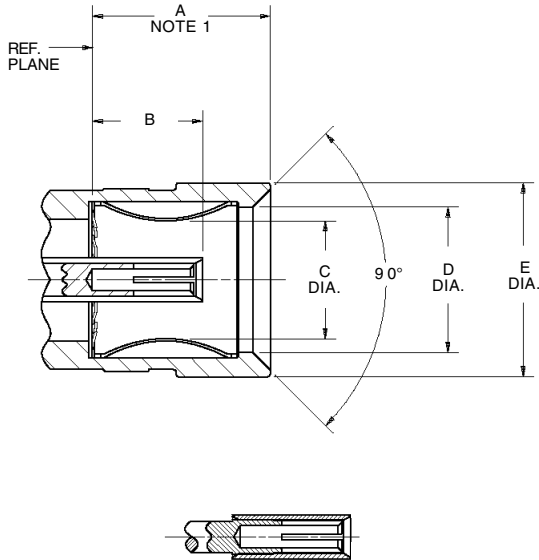

CLOSED TO MEET VSWR, MATING CHARACTERISTICS AND CONNECTOR DURABILITY WHEN MATED WITH APPROPRIATE MALE CONTACT.

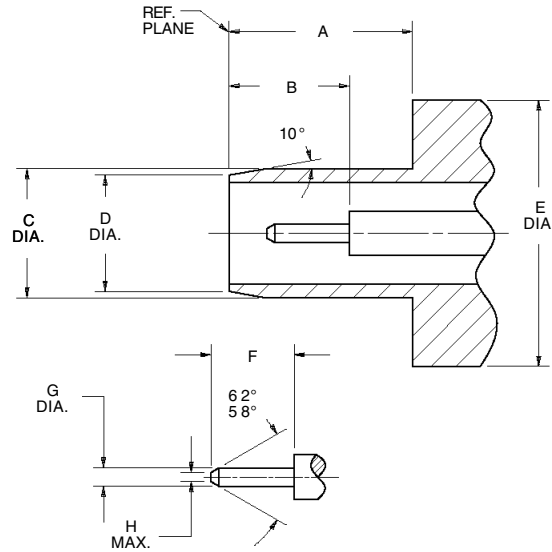

### Jack

Letter	Inches (Millimeters)
A	.197 Nom. (5.00)
B	.127 Max. (3.23)
C	.132 Max. (3.35)
D	.154 Min. (3.91)
E	.210 Ref. (5.33)

**NOTES:**

1. With spring finger bottomed.

### Plug

Letter	Inches (Millimeters)
A	.199 Min. (5.05)
B	.128 Min. (3.25)
C	.140 Nom. (3.56)
D	.126 Nom. (3.20)
E	.210 Ref. (5.33)
F	.090 Nom. (2.29)
G	.020 Nom. (.51)
H	.012 Max (.30)

Dimensions are in inches.  
Metric equivalents are given for general information only.

## Specifications

### General

Materials	Body, Stainless steel per AMS-5640, UNS S30300, Type I. Contact, Beryllium copper per ASTM-B-196. PTFE per ASTM-D-1710.
Finish	Body, Gold plated per ASTM-B-488 over nickel per SAE AMS-QQ-N-290, Class 1 or passivate. Center Contact, Gold plated per ASTM-B-488 over nickel per SAE AMS-QQ-N-290, Class 1.
Design	Interface dimensions per MIL-STD-348.

### Electrical

	<b>RG 405 (.085) Semi-Rigid</b>
Frequency	DC to 28 GHz
Nominal Impedance	50 Ohms
VSWR	1.05 + .01f (GHz)
RF Transmission Loss	.040 x $\sqrt{f}$ (GHz)
Insulation Resistance	5,000 Megohms Min.
Contact Resistance	
Center Contact	6.0 Milliohms Max.
Outer Contact	3.0 Milliohms Max.
Outer Contact to Cable	0.5 Milliohms Max.
Dielectric Withstanding Voltage	675 Volts RMS
Corona Extinction Voltage at 70,000 Ft.	250 Volts Min.
RF High Potential at 5 MHz	675 Volts RMS
RF Leakage Interface Only	-(90-fGHz) dB Min. (fully mated)

### Mechanical

Force to Engage	48 Ounces Max.
Force to Disengage	1.5 Pounds Max.
Center Contact Retention	4 Pounds Min.
Durability	5,000 Cycles
Radial Misalignment	
Rigid Mount	±.0025 Inch
Float Mount	±.020 Inch

### Environmental

Temperature Rating	-65°C to +125°C (Semi-Rigid)
Corrosion (Salt Spray)	MIL-STD-202, Method 101, Condition B
Vibration	MIL-STD-202, Method 204, Condition D, 20 Gs
Shock	MIL-STD-202, Method 213, Condition I, 100 Gs
Thermal Shock	MIL-STD-202, Method 107, Condition B, -65°C to +125°C
Moisture Resistance	MIL-STD-202, Method 106, Less Step 7B
Barometric Pressure (Altitude)	MIL-STD-202, Method 105, Condition C, 70,000 Ft.

## Semi-Rigid Cable • Direct Solder Attachment

### Bulkhead Feedthrough Cable Plug Rear Mount

Cable	RG-405/U (.085)
Part Number	<b>1408-6002</b>

Finish: Gold plated.  
See Recommended Mounting Hole Detail H in Appendix A.

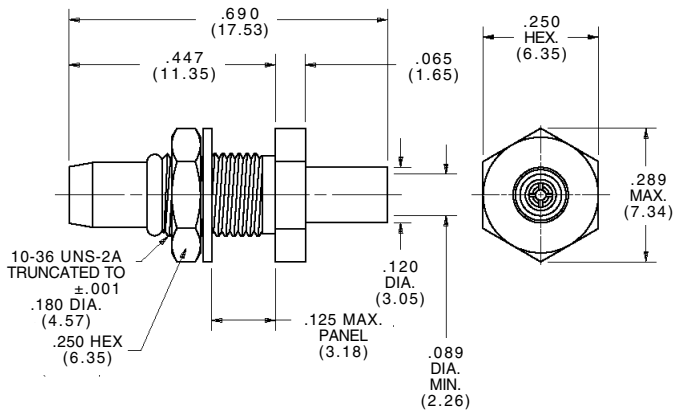

### Bulkhead Feedthrough Cable Jack Rear Mount

Cable	RG-405/U (.085)
Part Number	<b>1444-6001</b>

Finish: Gold plated.  
See Recommended Mounting Hole Detail C in Appendix A.

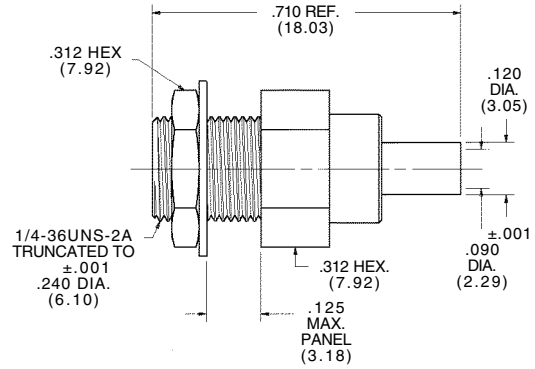

### Low Profile • Panel Feedthrough Cable Jack • Floating Rear Mount

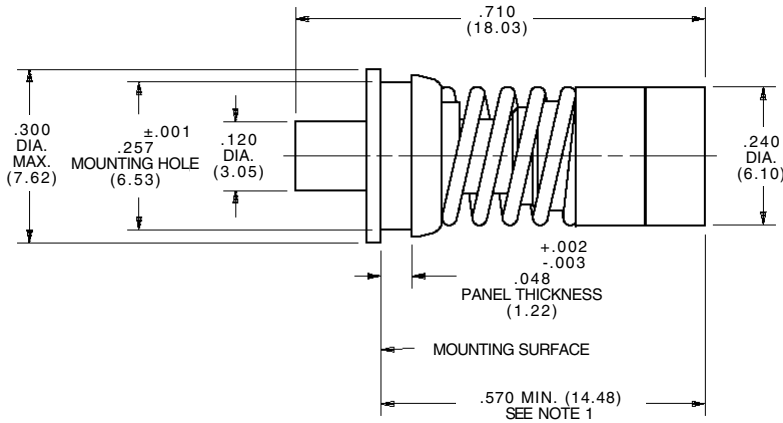

Cable	RG-405/U (.085)
Part Number	<b>1440-6001</b>

Finish: Gold plated.  
See Recommended Mounting Hole Detail G in Appendix A.  
NOTE 1: With .060 Min. (1.52) axial float.

## Between-Series Adapters

Description	Part Number
SMA Jack to BMMA Jack	<b>SF1114-6005</b>
SMA Plug to BMMA Jack	<b>SF1114-6006</b>
SMA Plug to BMMA Plug	<b>SF1114-6007</b>
SMA Jack to BMMA Plug	<b>SF-1114-6008</b>

Finish: BMMA and SMA are passivated stainless steel.

## BMMA Removal Tool

Part Number	<b>500-14-000</b>
-------------	-------------------

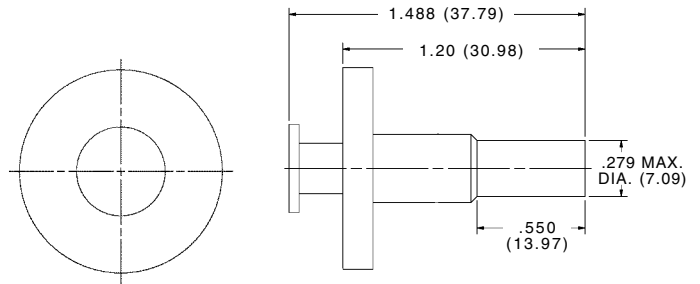

## Interface Mating Dimensions

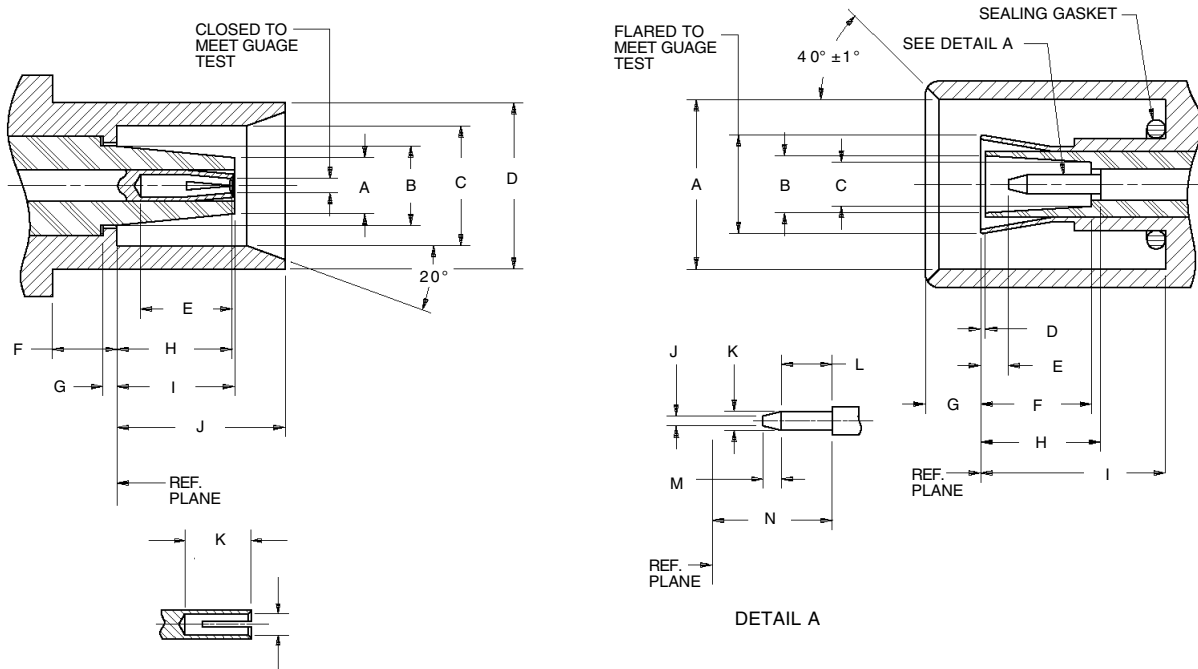

CLOSED TO MEET VSWR, MATING CHARACTERISTICS AND CONNECTOR DURABILITY WHEN MATED WITH APPROPRIATE MALE CONTACT.

### Jack

Letter	Inches (Millimeters)
A	.062 Max. (1.57)
B	.087 Max. (2.21)
C	.129 Min. (3.28)
D	.188 Max. (4.78)
E	.095 Min. (2.41)
F	.070 Min. (1.78)
G	.010 Max. (.25)
H	.130 Max. (3.30)
I	.130 Max. (3.30)
J	.188 Max. (4.78)
K	.105 Min. (2.63)

### Plug

Letter	Inches (Millimeters)
A	.184 Min. (4.67)
B	.087 Min. (2.21)
C	.062 Min. (1.57)
D	.010 Max. (.25)
E	.030 Min. (.76)
F	.130 Min. (3.30)
G	.065 Min. (1.65)
H	.130 Min. (3.30)
I	.203 Max. (5.16)
J	.011 Max. (.28)
K	.021 Max. (.53)
L	.060 Min. (1.52)
M	.015 Min. (.38)
N	.130 Min. (3.30)

Dimensions are in inches.  
Metric equivalents are given for general information only.

## Specifications

### General

Materials	Body, Stainless steel per AMS-5640, UNS S30300, Type I. Contact, Beryllium copper per ASTM-B-196. PFTE per ASTM-D-1710.
Finish	Body, Gold plated per ASTM-B-488 over nickel per SAE AMS-QQ-N-290, Class 1 or passivate. Center Contact, Gold plated per ASTM-B-488 over nickel per SAE AMS-QQ-N-290, Class 1.
Design	Interface dimensions per MIL-STD-348.

### Electrical

	<b>RG 405 (.085) Semi-Rigid</b>
Frequency	DC to 18 GHz
Nominal Impedance	50 Ohms
VSWR	1.05 + .01f (GHz)
RF Transmission Loss	.06 x $\sqrt{f}$ (GHz)
Insulation Resistance	10,000 Megohms Min.
Contact Resistance	
Center Contact	6.0 Milliohms Max.
Outer Contact	3.0 Milliohms Max.
Outer Contact to Cable	0.5 Milliohms Max.
Dielectric Withstanding Voltage	1,000 Volts RMS
Corona Extinction Voltage at 70,000 Ft.	250 Volts Min.
RF High Potential at 5 MHz	500 Volts RMS
RF Leakage Interface Only	-(80-fGHz) dB Min. (fully mated)

### Mechanical

Force to Engage	12 Ounces Max.
Force to Disengage	2 Ounces Min.
Center Contact Retention	6 Pounds Min.
Durability	500 Cycles
Radial Misalignment	
Rigid Mount	± .0025 Inch
Float Mount	± .020 Inch

### Environmental

Temperature Rating	-65°C to +125°C (Semi-Rigid)
Corrosion (Salt Spray)	MIL-STD-202, Method 101, Condition B
Vibration	MIL-STD-202, Method 204, Condition D, 20 Gs
Shock	MIL-STD-202, Method 213, Condition I, 100 Gs
Thermal Shock	MIL-STD-202, Method 107, Condition B, -65°C to +125°C
Moisture Resistance	MIL-STD-202, Method 106, Less Step 7B
Barometric Pressure (Altitude)	MIL-STD-202, Method 105, Condition C, 70,000 Ft.



# BMZ BLINDMATE CONNECTORS DC to 18 GHz

## Semi-Rigid Cable • Direct Solder Attachment

### Flange Mount Cable Jack • Rear Mount

Cable	RG-405/U (.085)
Part Number	<b>SF8934-6001</b>

Finish: Inner housing that is soldered to cable is gold plated. Outer housing is passivated stainless steel.  
Refer to Recommended Mounting Hole Detail N in Appendix A.

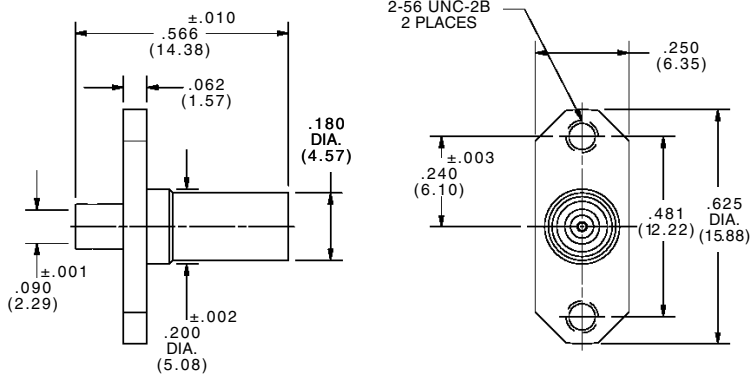

### Flange Mount Cable Plug • Floating Rear Mount

Cable	RG-405/U (.085)	RG-402/U (.141)
Part Number	<b>SF8903-6001</b>	<b>SF8901-6003</b>

Flange shroud will rotate a full  $360^\circ$  for optimum alignment prior to mounting. Finish: Inner housing that is soldered to cable is gold plated. Outer housing is passivated stainless steel.  
Refer to Recommended Mounting Hole Detail B in Appendix A.

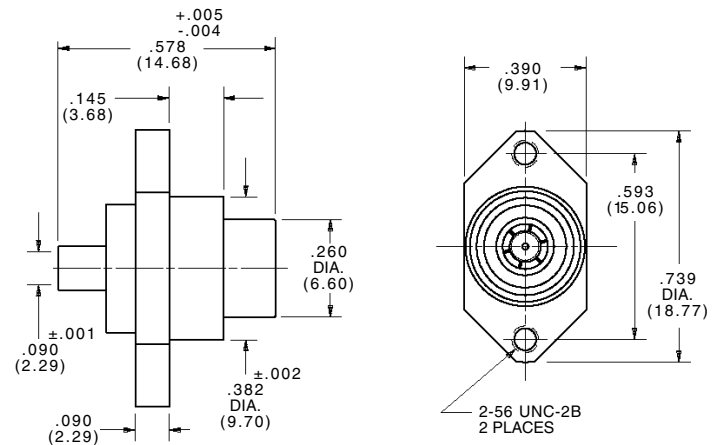

### Flange Mount Right Angle Cable Plug Floating Rear Mount

Cable	RG-402/U (.141)
Part Number	<b>SF8958-6000</b>

Flange shroud will rotate a full  $360^\circ$  for optimum alignment prior to mounting. Finish: Inner housing that is soldered to cable is gold plated. Outer housing is passivated stainless steel.  
Refer to Recommended Mounting Hole Detail B in Appendix A.

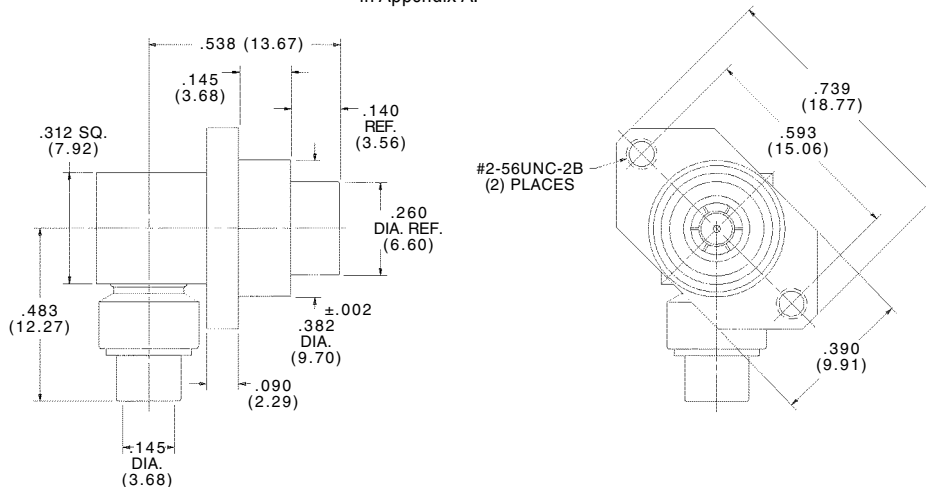

## Flexible Cable • Clamp Attachment

### Flange Mount Cable Plug • Floating Rear Mount

Cable	RD-316
Part Number	<b>SF8961-6010</b>

Flange shroud will rotate a full 360° for optimum alignment prior to mounting.  
 Finish: Passivated stainless steel.  
 Refer to Recommended Mounting Hole Detail B in Appendix A.

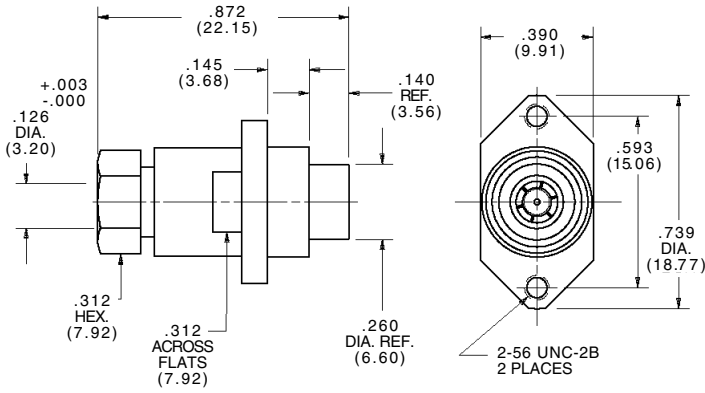

### Flange Mount Cable Jack • Rear Mount

Cable	RD-316
Commercial Part No.	<b>SF8931-6006</b>
DSCC Drawing 91012ZSP-3	<b>SF8931-6005</b>

Finish: Passivated stainless steel.  
 Refer to Recommended Mounting Hole Detail N in Appendix A.

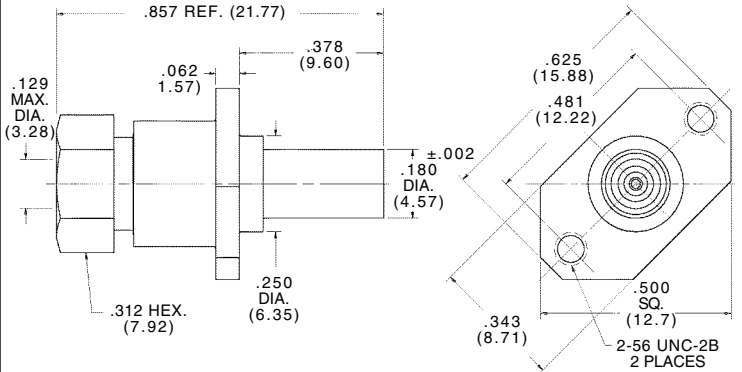

### Flange Mount Right Angle Cable Plug Floating Rear Mount

Cable	RG-178	RG-196	RD-316
Commercial Part No.	<b>SF8961-6008</b>	<b>SF8961-6002</b>	<b>SF8961-6014</b>
DSCC Drawing 91013ZSP-3	—	—	<b>SF8961-6005</b>
Dim. A	Inches(mm) .102 Max. (2.59)	Inches(mm) .118 Max. (2.30)	Inches(mm) .129 Max. (3.28)

Flange shroud will rotate a full 360° for optimum alignment prior to mounting.  
 Finish: Passivated stainless steel.  
 See Recommended Mounting Hole Detail B in Appendix A.

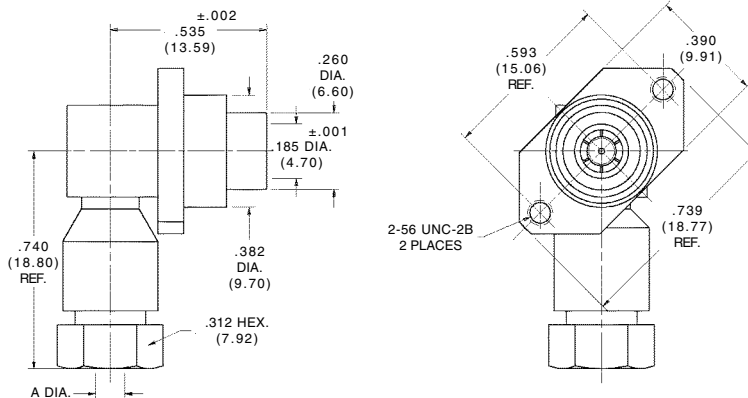

## Panel Mount • Tab Terminal

### Flange Mount Jack Receptacle

Part Number **SF8961-6006**

Finish: Passivated stainless steel.  
See Recommended Mounting Hole Detail N in Appendix A.

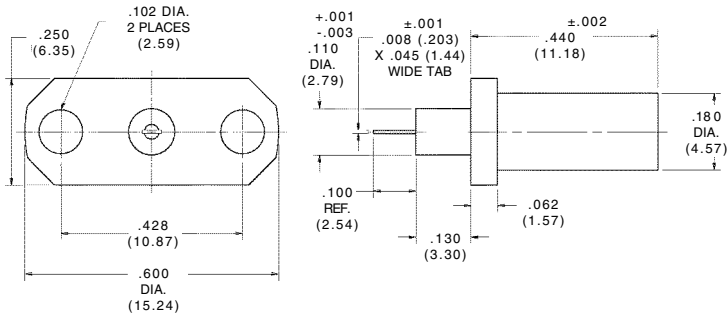

## Panel Mount • Straight Terminal

### Flange Mount Jack Receptacle

Part Number **SF8953-6100**

Finish: Passivated stainless steel.  
See Recommended Mounting Hole Detail N in Appendix A.

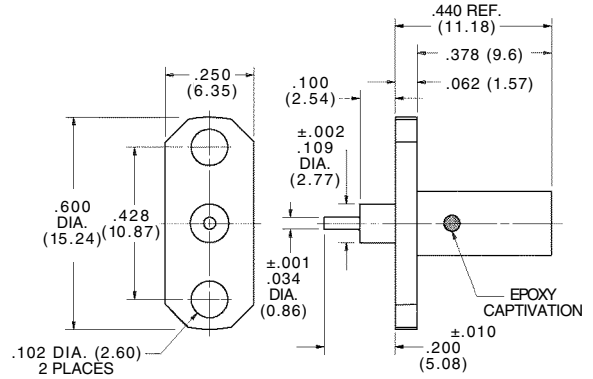

## Panel Mount • Solder Pot Terminal

### Flange Mount Jack Receptacle

Part Number **SF8950-6003**

Finish: Passivated stainless steel.  
See Recommended Mounting Hole Detail N in Appendix A.

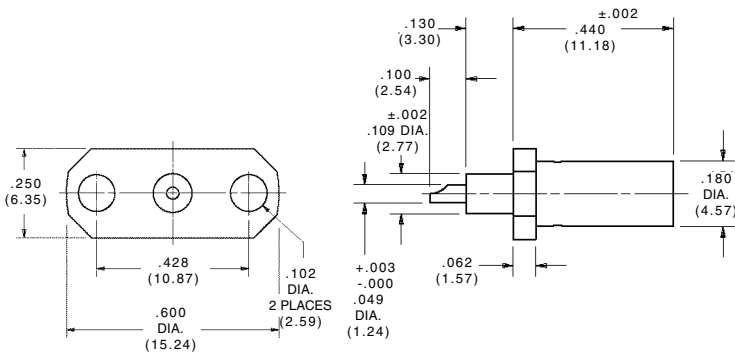

## Panel Mount • EMI Gasket

### Flange Mount Jack Receptacle Accepts .014 – .017 Dia Pin

Part Number	<b>SF8961-6012</b>
-------------	--------------------

Finish: Passivated stainless steel.  
See Recommended Mounting Hole Detail R in Appendix A.

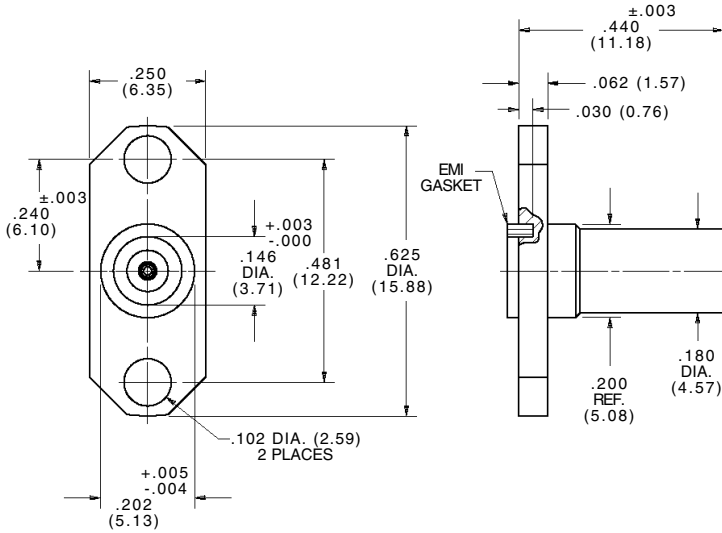

## Between-Series Adapters

Description	Part Number
SMA Jack to BMZ Jack	<b>SF1189-6001</b>
SMA Plug to BMZ Jack	<b>SF1189-6104</b>
SMA Plug to BMZ Plug	<b>SF1189-6009</b>
SMA Jack to BMZ Plug	<b>SF1189-6103</b>

Finish: BMZ and SMA are passivated stainless steel.

## BMZ Removal Tool

Part Number	<b>500-89-000</b>
-------------	-------------------

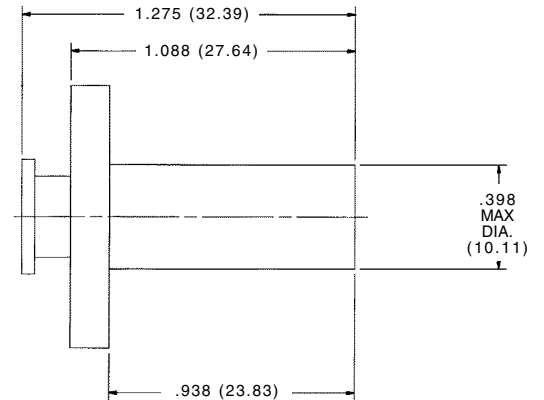

## Interface Mating Dimensions

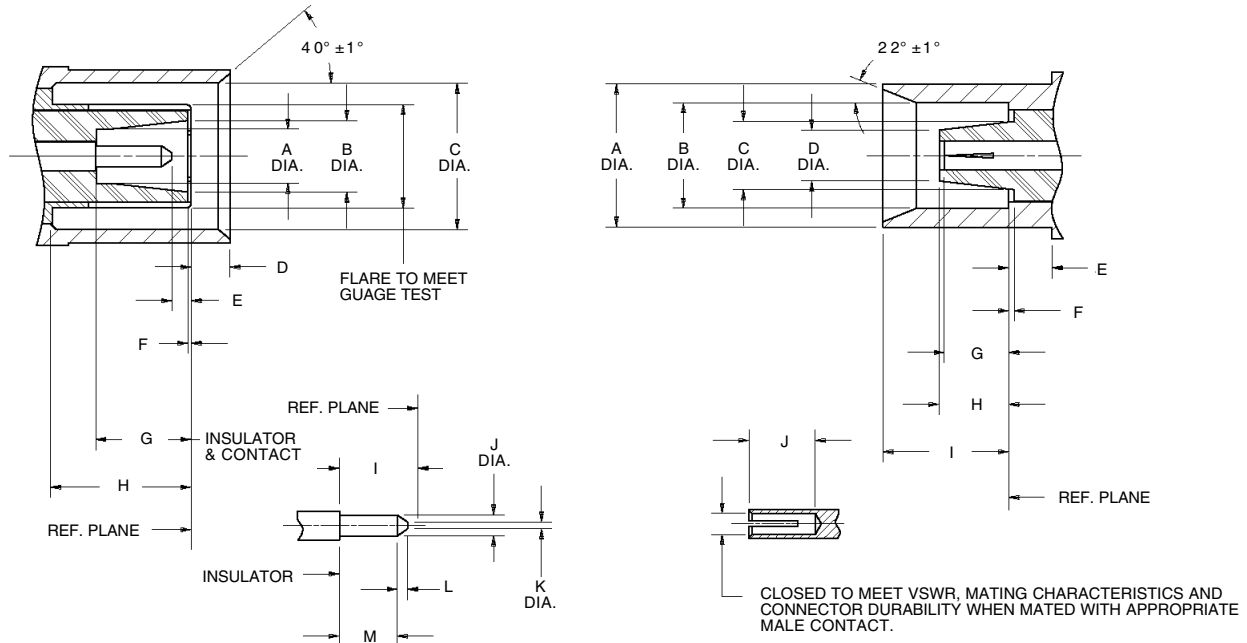

### Plug

Letter	Inches (Millimeters)
A	.090 Min. (2.29)
B	.122 Min. (3.10)
C	.251 Min. (6.38)
D	.072 Max. (1.83)
E	.020 Min. (.51)
F	.010 Max. (.25)
G	.130 Min. (3.30)
H	.250 Max. (6.35)
I	.130 Min. (.70)
J	.037 Max. (.94)
K	.015 Max. (.38)
L	.015 Min. (3.8)
M	.060 Min. (1.52)

### Jack

Letter	Inches (Millimeters)
A	.249 Max. (6.32)
B	.182 Min. (4.62)
C	.122 Max. (3.10)
D	.090 Max. (2.29)
E	.075 Min. (1.91)
F	.010 Max. (.25)
G	.132 Max. (3.35)
H	.132 Max. (3.35)
I	.221 Max. (5.61)
J	.105 Min. (2.63)

Dimensions are in inches.  
Metric equivalents are given for general information only.

## Specifications

### General

Materials	Body , Stainless steel per AMS-5640, UNS S30300, Type I. Contact, Beryllium copper per ASTM-B-196. PTFE per ASTM-D-17107
Finish	Body, Gold plated per ASTM-B-488 over nickel per SAE AMS-QQ-N-290, Class or passivate. Center Contact, Gold plated per ASTM-B-488 over nickel per SAE AMS-QQ-N-290, Class 1.

### Electrical

	<b>RG 402 (.141) Semi-Rigid</b>	<b>RG 405 (.085) Semi-Rigid</b>
Frequency	DC to 2 GHz (DC to 12.4 and 18 GHz units are available.)	DC to 2 GHz
Nominal Impedance	50 Ohms	50 Ohms
VSWR	1.02 + .005f (GHz)	1.05 + .005f (GHz)
RF Transmission Loss	.03x√f (GHz)	.03x√f (GHz)
Insulation Resistance	5,000 Megohms Min.	5,000 Megohms Min.
Contact Resistance		
Center Contact	2.0 Milliohms Max.	2.0 Milliohms Max.
Outer Contact	2.0 Milliohms Max.	2.0 Milliohms Max.
Dielectric Withstanding Voltage	1500 Volts RMS	1000 Volts RMS
Corona Extinction Voltage at 70,000 Ft.	375 Volts Min.	335 Volts Min.
RF HighPotential at 5 MHz	1,000 Volts RMS	670 Volts RMS
RF Leakage Interface Only	-(90-fGHz) dB Min. (fully mated)	-(90-fGHz) dB min. (fully mated)

### Mechanical

Force to Engage	32 Ounces Max.
Force to Disengage	20 Ounces Min.
Center Contact Retention	6 Pounds Min.
Durability	500 Cycles
Radial Misalignment	
Rigid Mount	± .004 Inch
Float Mount	± .020 Inch

### Environmental

Temperature Rating	-65°C to +125°C (Semi-Rigid)
Corrosion (Salt Spray)	MIL-STD-202, Method 101, Condition B
Vibration	MIL-STD-202, Method 204, Condition D, 20 Gs
Shock	MIL-STD-202, Method 213, Condition I, 100 Gs
Thermal Shock	MIL-STD-202, Method 107, Condition B, -65°C to +125°C
Moisture Resistance	MIL-STD-202, Method 106, Less Step 7B
Barometric Pressure (Altitude)	MIL-STD-202, Method 105, Condition C, 70,000 Ft.



## Semi-Rigid Cable • Direct Solder Attachment

### Low Profile • Bulkhead Feedthrough Cable Plug Floating Rear Mount

Cable	RG-405/U (.085)	RG-402/U (.141)
Part Number	<b>SF8806-6006</b>	<b>SF8802-6007</b>
Dim. A	Inches (mm) .090 (2.29)	Inches (mm) .145 (3.68)

Finish: Housing that is soldered to cable outer conductor is gold plated.  
Refer to Recommended Mounting Hole Detail F in Appendix A.

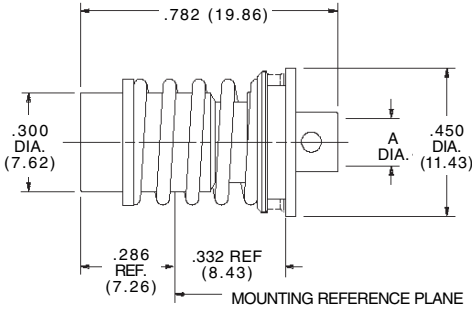

### Flange Mount Cable Jack Fixed Rear Mount

Cable	RG-405/U (.085)	RG-402/U (.141)
Frequency	DC to 2 GHz	DC to 18 GHz
Power	—	7 kW @ 2 GHz
Part Number	<b>SF8820-6001</b>	<b>SF8835-6000</b>
Dim. A	Inches (mm) .120 (3.05)	Inches (mm) .180 (4.57)
Dim. B	.090 (2.29)	.146 (3.71)

Finish: Housing that is soldered to cable outer conductor is gold plated.  
Refer to Recommended Mounting Hole Detail R in Appendix A.

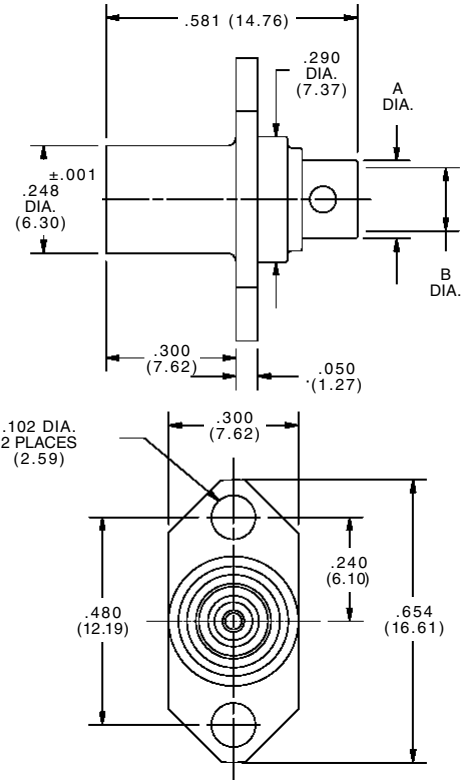

## In-Series Adapters

### Plug to Plug

Part Number	<b>SF8890-6001</b>
Power	7 kW

Finish: Passivated stainless steel

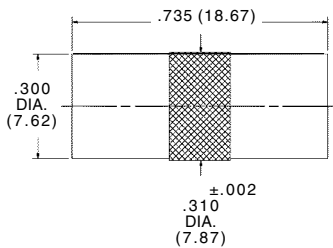

## Snap-In Plug Termination

Part Number	<b>SF8088-6001</b>
Power Avg. (Watts)	1.0*

Finish: Passivated stainless steel.  
See Recommended Mounting Hole Detail F in Appendix A.  
\*Power derated linearly to 10% power at 125°C.

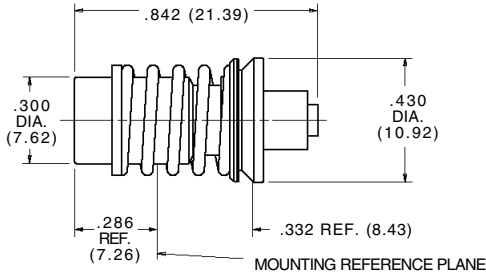

## Flange Mount Jack Termination

Part Number	<b>SF8088-6002</b>
Power Avg. (Watts)	1.0*

Finish: Passivated stainless steel.  
See Recommended Mounting Hole Detail R in Appendix A.  
\*Power derated linearly to 10% power at 125°C.

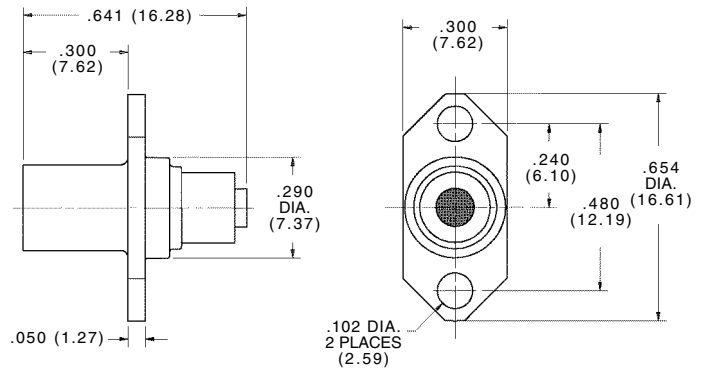

## Between-Series Adapters

Description	Part Number
SMA Jack to BZ Jack	<b>SF1122-6108</b>
SMA Plug to BZ Jack	<b>SF1122-6106</b>
SMA Plug to BZ Plug	<b>SF1122-6102</b>
SMA Jack to BZ Plug	<b>SF1122-6101</b>
3.5mm Jack to BZ Jack	<b>SF1188-6003</b>
3.5mm Plug to BZ Jack	<b>SF1188-6002</b>

Finish: BZ to SMA are passivated stainless steel.  
BZ to 3.5mm are gold plate.

## BZ Removal Tool

Part Number	<b>500-88-002</b>
-------------	-------------------

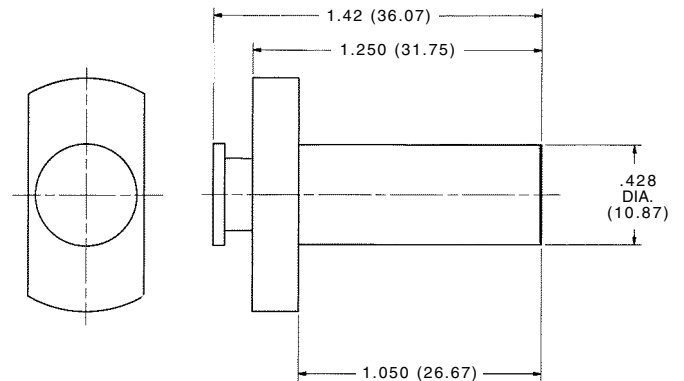

BZ Calibration Kit available. Contact factory.

# BLINDMATE CONNECTORS • Appendix A

## Recommended Mounting Hole Details\*

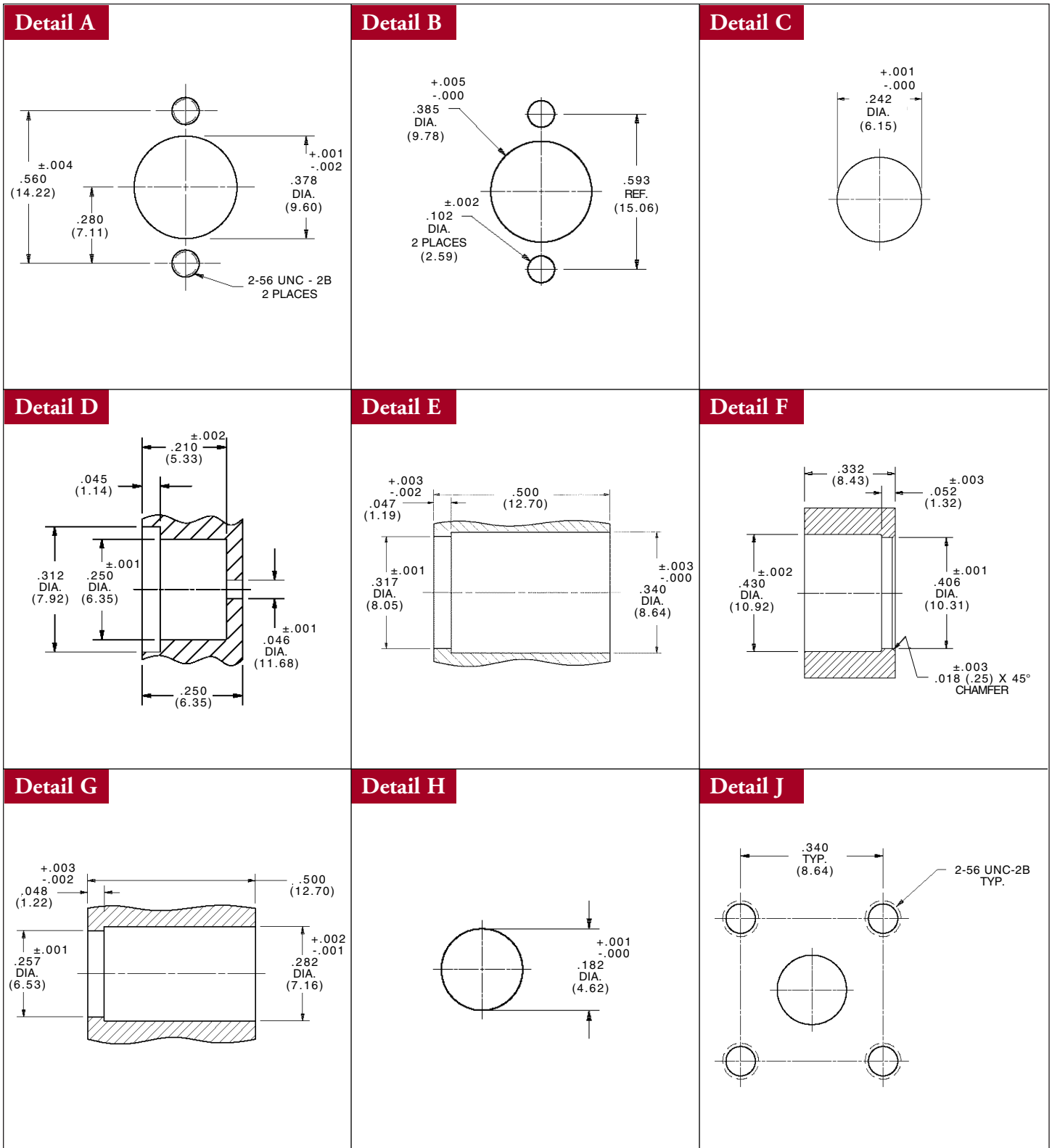

\*Consult factory for complete details.

# BLINDMATE CONNECTORS Appendix A

## Recommended Mounting Hole Details\*

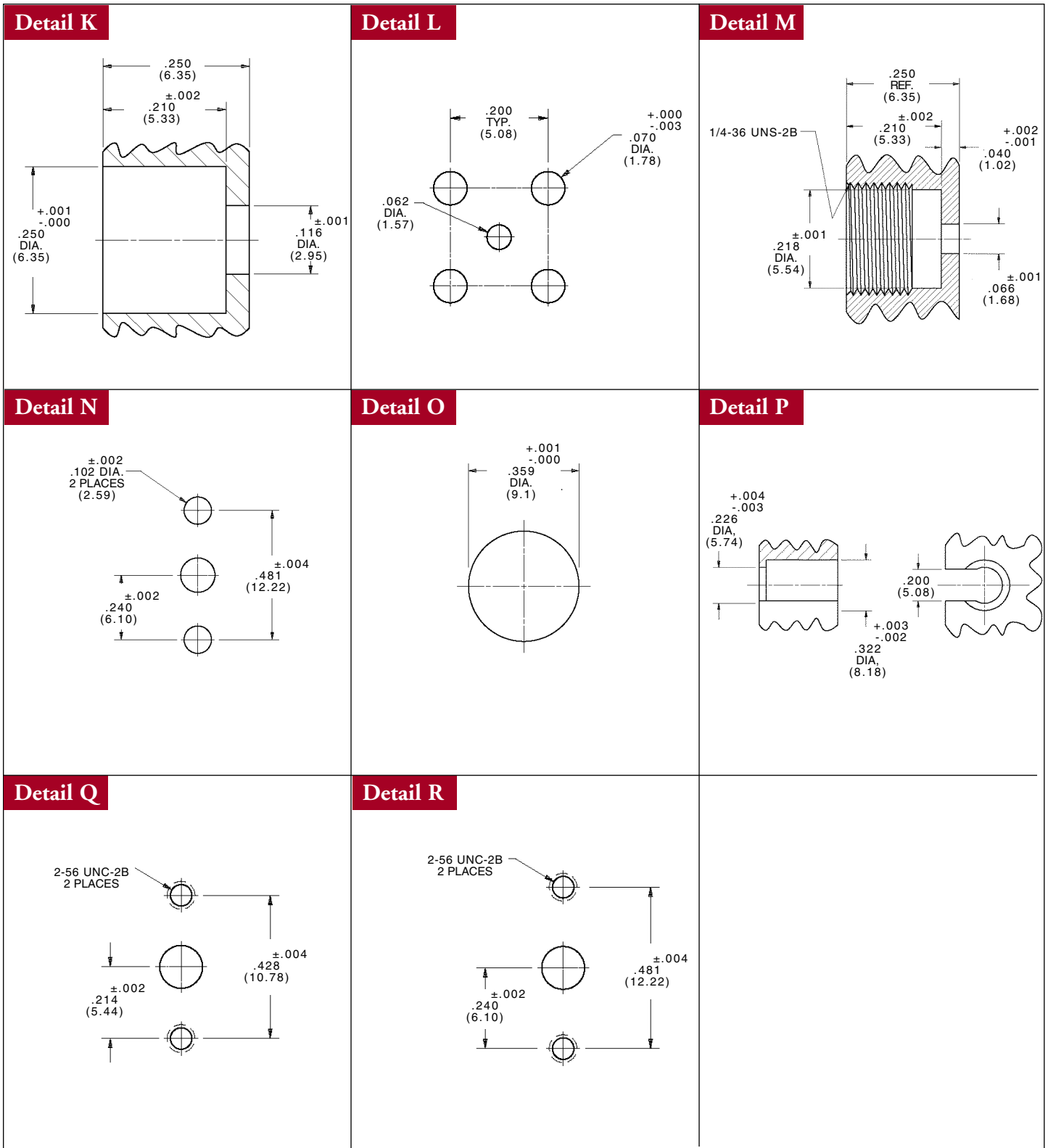

\*Consult factory for complete details.

# BLINDMATE CONNECTORS AND COMPONENTS

## Part Number Index

SF1114-6005	.16	1778-6000	.11
SF1114-6006	.16	1785-0003	.11
SF1114-6007	.16	1785-6001	.10
SF1114-6008	.16	1789-6001	.11
SF1122-6101	.26	M31031/01-A5N01	.9
SF1122-6102	.26	M31031/01-A5N02	.9
SF1122-6106	.26	M31031/02-E5N01	.9
SF1122-6108	.26	M31031/02-E5N02	.9
1139-6004	.12	M31031/11-E5N01	.8
1139-6005	.12	M31031/11-E5N02	.8
SF1157-6009	.12	M31031/12-E5N01	.8
SF1158-6001	.12	M31031/12-E5N02	.8
SF1175-6010	.12	500-14-000	.16
SF1175-6013	.12	500-17-000	.12
SF1188-6002	.26	500-88-002	.26
SF1188-6003	.26	500-89-000	.22
SF1189-6001	.22	SF8017-6001	.12
SF1189-6009	.22	8017-6002	.12
SF1189-6103	.22	SF8802-6007	.25
SF1189-6104	.22	SF8806-6006	.25
1408-6002	.15	8088-6001	.26
1440-6001	.15	8088-6002	.26
1444-6001	.15	SF8820-6001	.25
1708-0001	.8	SF8835-6000	.25
1708-6003	.8	SF8890-6001	.25
SF1708-6301	.9	SF8901-6003	.19
SF1708-6302	.9	SF8903-6001	.19
1709-6002	.8	SF8931-6005	.20
SF1721-6002	.9	SF8931-6006	.20
SF1732-6004	.8	SF8934-6001	.19
SF1733-6006	.8	SF8950-6003	.21
1733-6008	.8	SF8953-6100	.21
SF1738-6001	.9	SF8958-6000	.19
SF1738-6002	.9	SF8961-6002	.20
1740-6001	.8	SF8961-6005	.20
1742-6002	.8	SF8961-6006	.21
SF1750-6101	.10	SF8961-6008	.20
SF1755-6104	.10	SF8961-6010	.20
SF1755-6105	.10	SF8961-6012	.22
SF1769-6501	.9	SF8961-6014	.20
SF1772-6005	.10	91012ZSP-3	.20
SF1774-6001	.10	91013ZSP-3	.20

Visit our website for more information on...

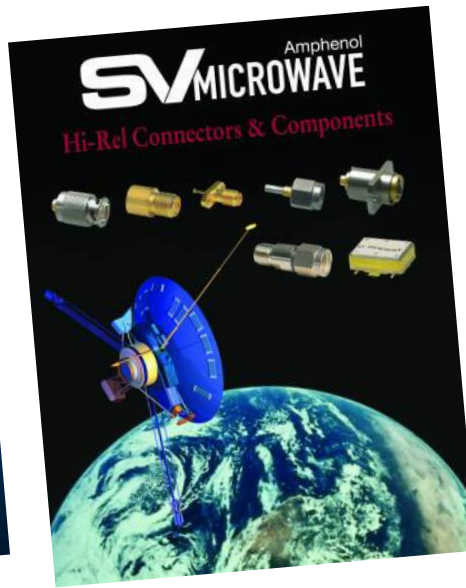

2400 Centrepark West Drive  
West Palm Beach, FL 33409

[www.svmicrowave.com](http://www.svmicrowave.com)