

Mini-D RF Connection System

A Better **RF** Connection

Features & Benefits

- High Frequency RF performance to 67 GHz
- High density design (.110" port-to-port spacing)
- Proven SMPS interface
- SMPS interface recessed from D-Sub housing to protect from damage
- Rugged lightweight aluminum housing
- PCB Edge Mount and Surface Mount connector options available
- D-shaped design to avoid mis-mating
- Easy mating/de-mating with thumbscrews

Applications

- Military & Aerospace
- Airborne Radar
- Automated Test Equipment (ATE)
- Bench-Top Testing \ Product Evaluation Boards
- Test and Instrumentation

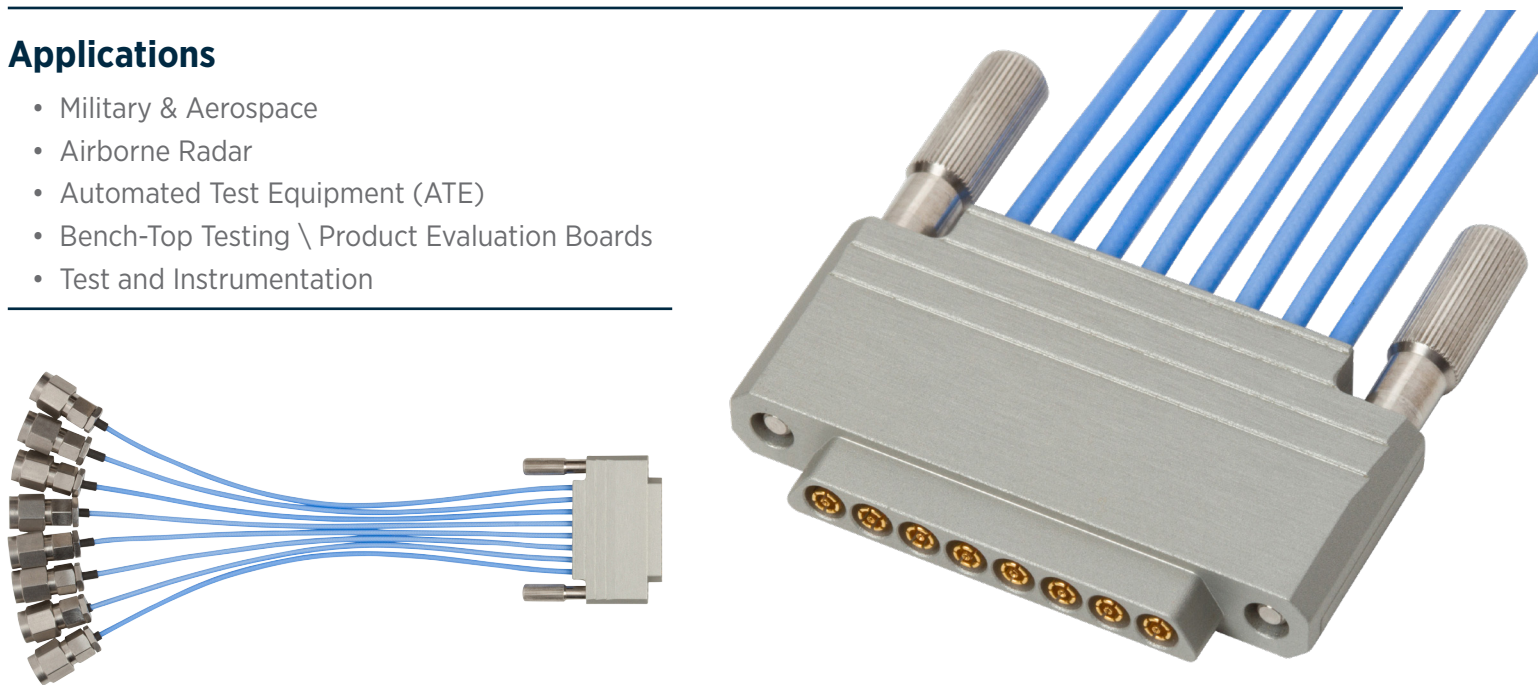

| Specifications | Mini-D RF Terminated to: | | | |
|--------------------------------|--|------------------|-------------------|------------------|
| Electrical | SMA | 2.92mm | 2.4mm | 1.85mm |
| Impedance | 50Ω | 50Ω | 50Ω | 50Ω |
| Max Frequency | 26.5 GHz | 40 GHz | 50 GHz | 65 GHz |
| VSWR (Max) | 1.2 : 1 @ 26.5 GHz | 1.3 : 1 @ 40 GHz | 1.35 : 1 @ 50 GHz | 1.4 : 1 @ 65 GHz |
| Mechanical | | | | |
| Insertion Force | 9 lbs (nominal) to mate 8 position cable connector to PCB mount | | | |
| Withdrawal Force | 7 lbs (nominal) to de-mate 8 position cable connector to PCB mount | | | |
| Recommended Mating Torque | 12 in - oz | | | |
| Recommended Board Mount Torque | 12 in - oz | | | |

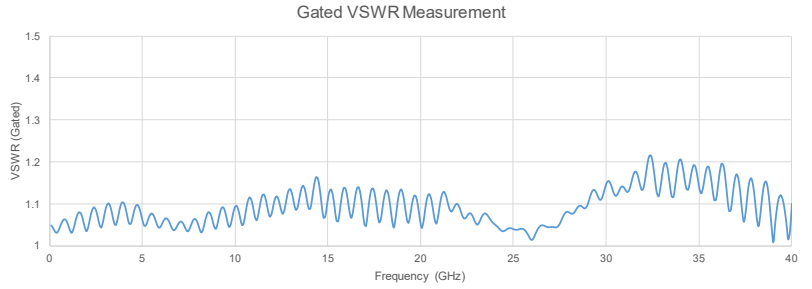
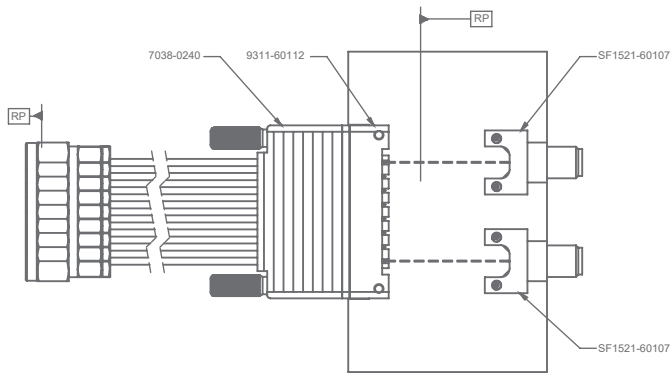

Gated VSWR measurement in above image consists of Mini-D RF cable assembly (7038-0240) and mating connector (9311-60112) plus ~.25" PCB after launch transition.

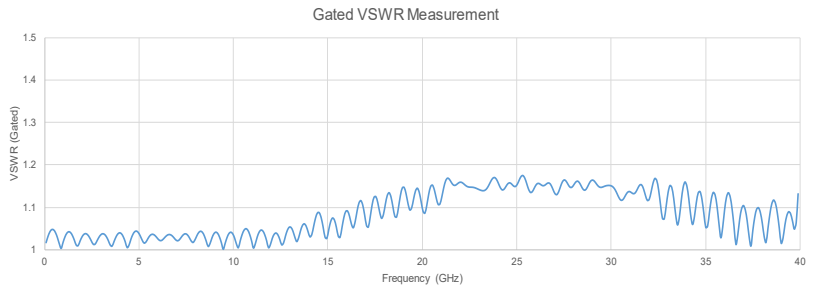
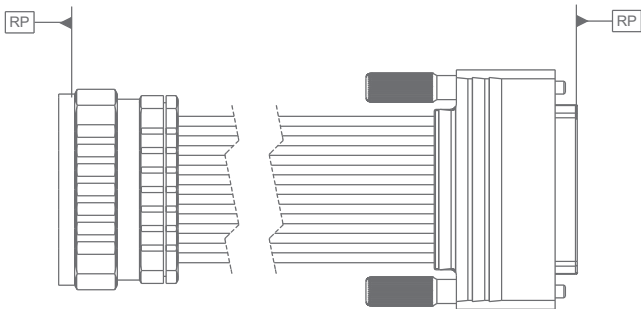

Gated VSWR measurement in above image consists of discrete 6" Mini-D RF cable.

Mini-D RF Standard Part Numbers

Mini-D RF Female to (8) 2.92mm Male Cable Assemblies for .047 Cable (OAL 6")

P/N: 7038-0211

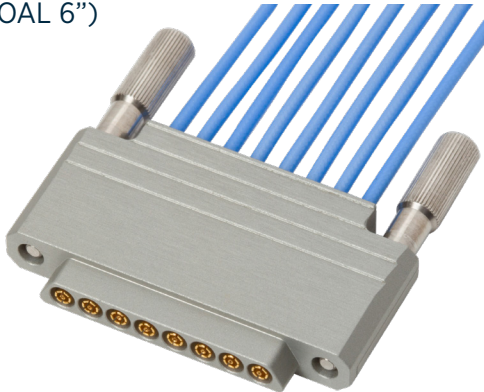

Mini-D RF Male PCB Edge Launch Connector, 8 Port

P/N: 9311-60112

Edge launch for CPW and microstrip PCB applications

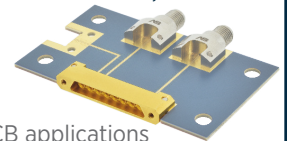

Mini-D RF Male PCB Surface Mount Connector, 8 Port

P/N: 9311-60128

Vertical launch with machined channels for use in CPW, microstrip or stripline PCB applications

