

PRODUCT DATA DRAWING

REVISION HISTORY			
REV.	DESCRIPTION	DATE	APPROVED
D	DCN 48136	11/18	STW

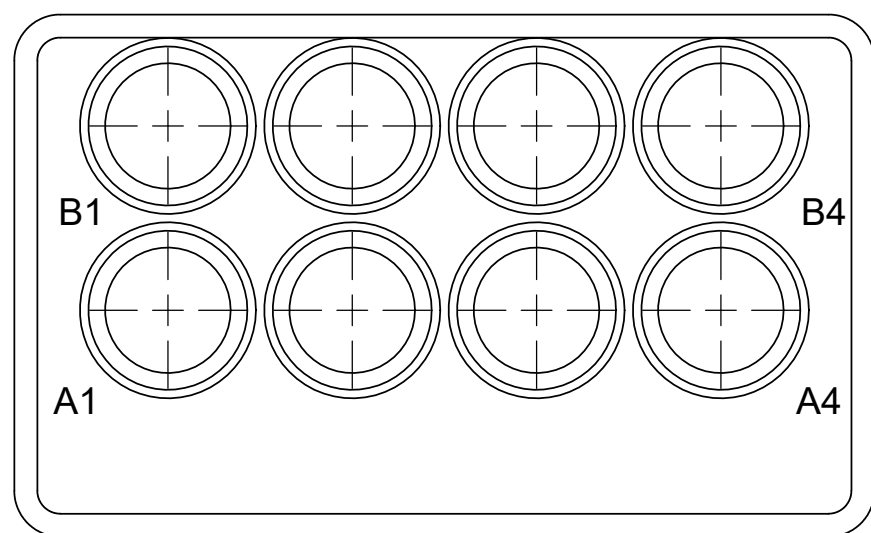

CAVITY IDENTIFICATION

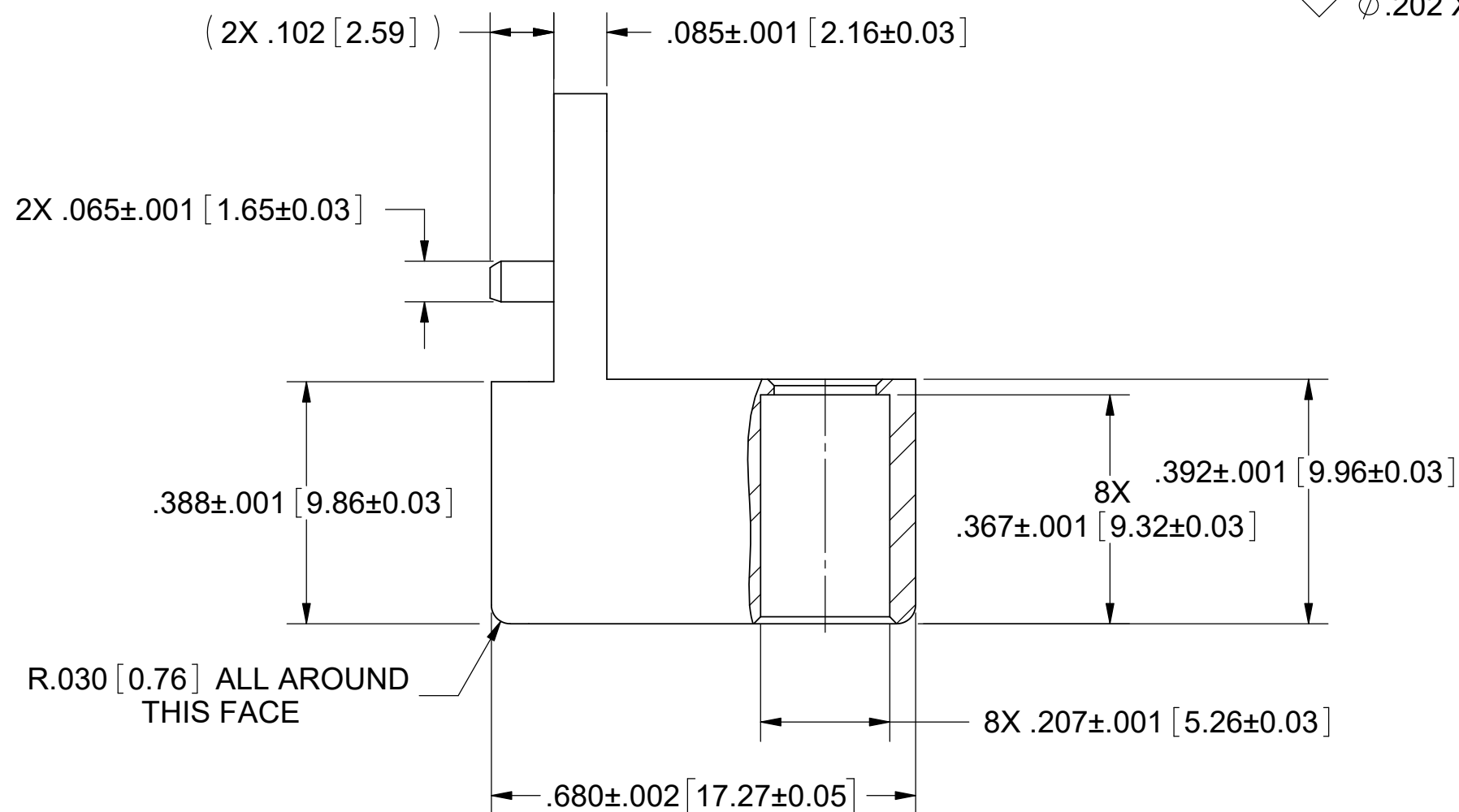
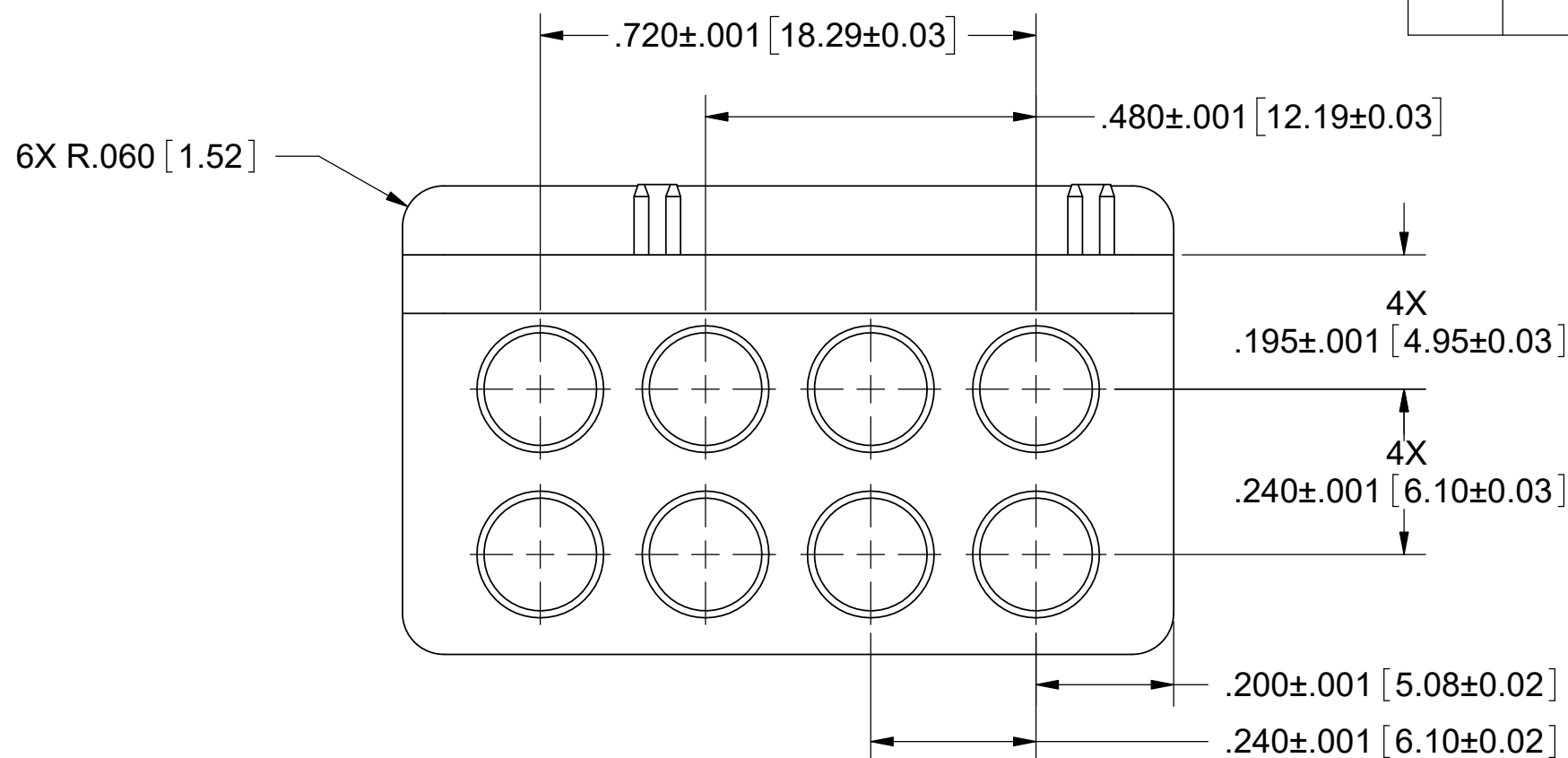

4X ϕ .102
 \checkmark ϕ .202 X 82° INCL.

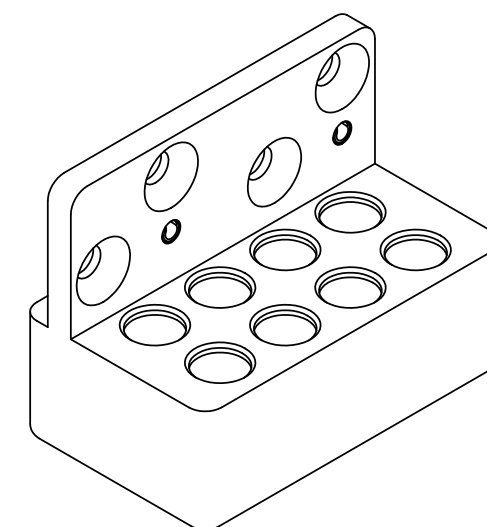
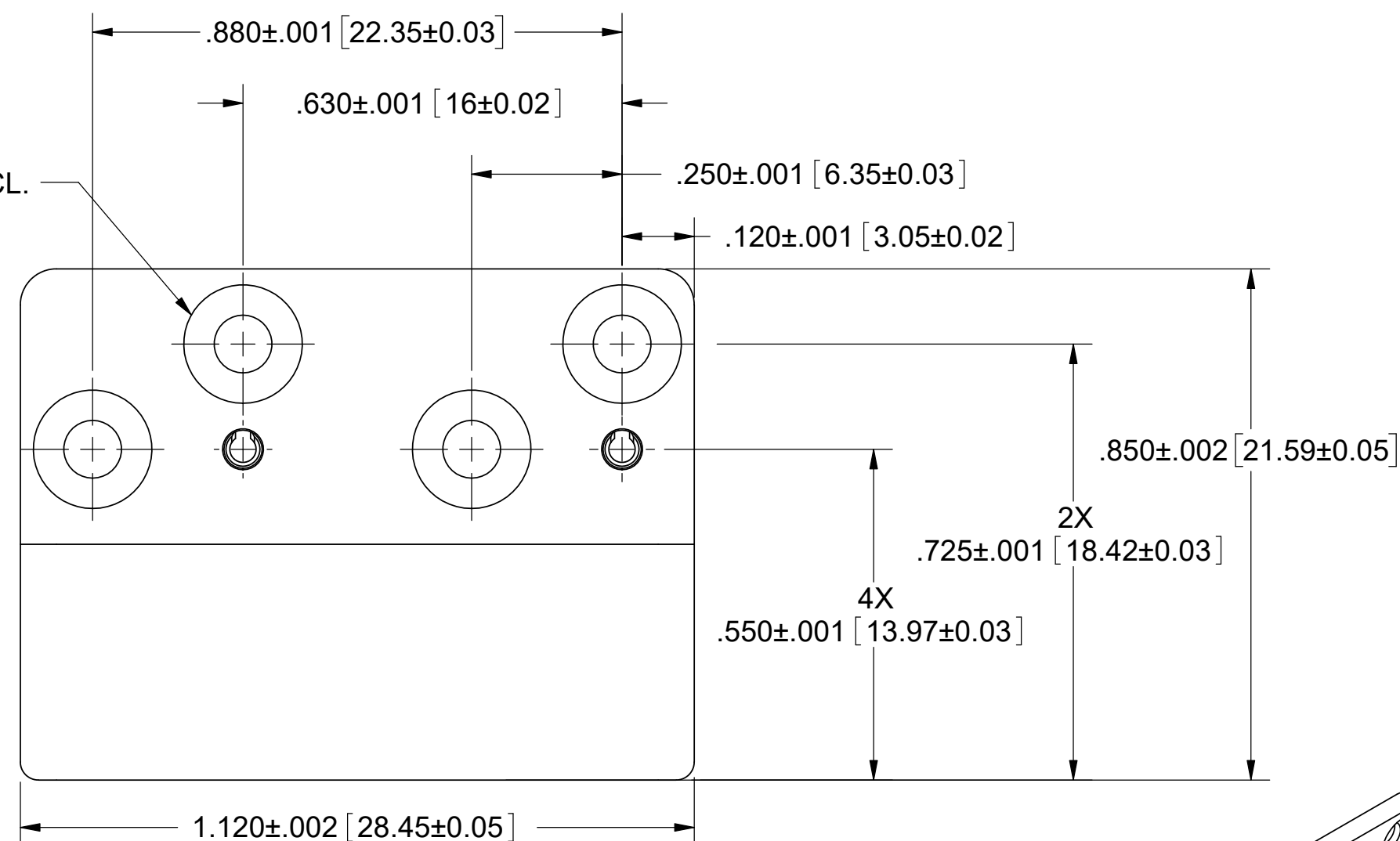

MATERIAL:
 MODULE: STAINLESS STEEL PER AMS-5640, ALLOY UNS S30300, TYPE 1
 SPRING PINS: STAINLESS STEEL PER ASTM A313, ALLOY UNS S30200, TYPE 302.
 FINISH:
 MODULE & SPRING PINS: PASSIVATED PER AMS-2700.

MATERIAL: SEE NOTES

FINISH: SEE NOTES

DO NOT SCALE DRAWING

PROPRIETARY

THE INFORMATION CONTAINED IN THIS DRAWING IS THE SOLE PROPERTY OF SV MICROWAVE, INC. ANY REPRODUCTION IN PART OR AS A WHOLE WITHOUT THE WRITTEN PERMISSION OF SV MICROWAVE, INC. IS PROHIBITED.

DIMENSIONS ARE IN INCHES

TOLERANCES:

ANGULAR: $\pm 1^\circ$

ONE PLACE DECIMAL $\pm .030$

TWO PLACE DECIMAL $\pm .010$

THREE PLACE DECIMAL $\pm .005$

INTERPRET DIMENSIONS AND TOLERANCES PER ASME Y14.5M - 1994

THIRD ANGLE PROJECTION



UNLESS OTHERWISE SPECIFIED:

1. ALL DIMENSIONS ARE AFTER PLATING.
2. BREAK CORNERS & EDGES R.005 MAX.
3. CHAMFER 1ST AND LAST THREAD.
4. SURFACE ROUGHNESS 63 PER MIL-STD-10.
5. DIA'S ON COMMON CENTERS TO BE CONCENTRIC WITHIN .005 T.I.R.
6. REMOVE ALL BURRS.

DRAWN: JMC 12/13/10

CHECKED: STW 02/07/11

APPROVED: STW 02/07/11

E.M. SIMULATION: N/A

SV Microwave, Inc.[®]

2400 Centrepark West Drive, Suite 100
 West Palm Beach, FL 33409

TITLE: **VITA 67.2 PLUG-IN
 8 PORT MODULE**

SIZE: **C** CAGE CODE: **95077**

DWG. NO. **SF9321-60013**

SCALE: 4:1

SHEET 1 OF 1