

# PRODUCT DATA DRAWING

REVISION HISTORY			
REV	DESCRIPTION	DATE	APPROVED
-	DCN 37960	01/11	STW
A	REV. DCN 50969	08/16/21	STW

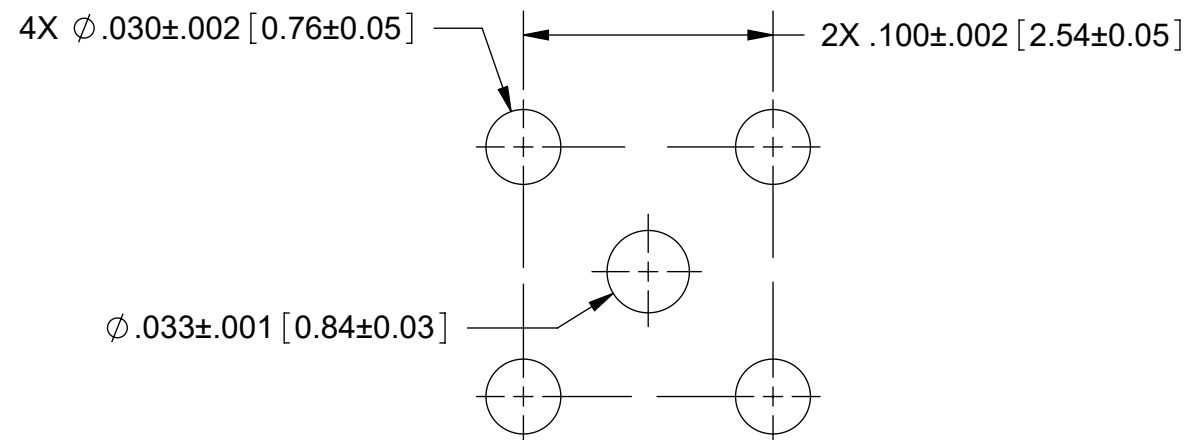

## RECOMMENDED MOUNTING HOLE PATTERN

### NOTES:

- FOR A FOOTPRINT RECOMMENDATION SPECIFIC TO YOUR PCB, PLEASE CONTACT US AT [applications@svmicro.com](mailto:applications@svmicro.com)

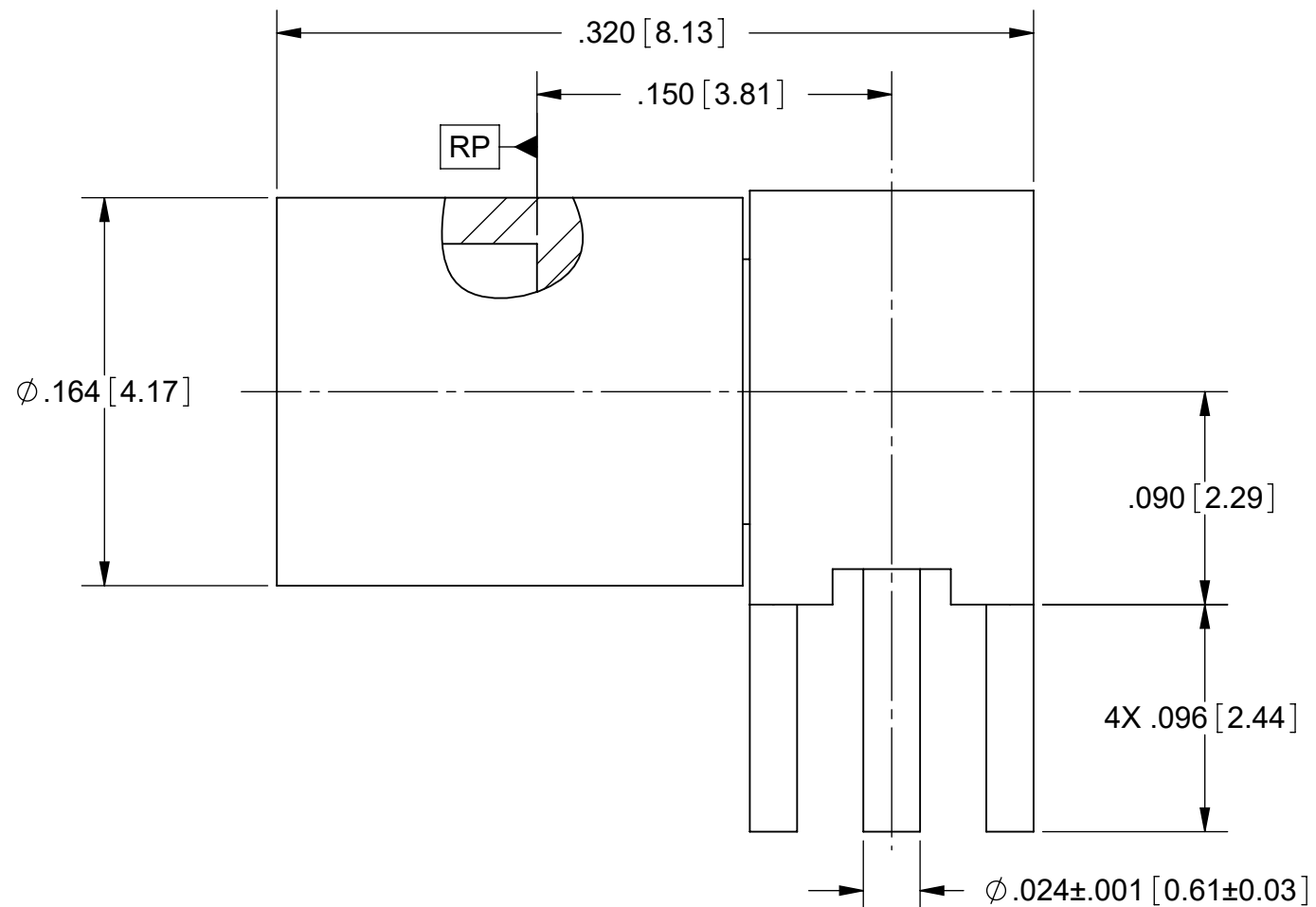

### MATERIAL:

INTERFACE BODY: STAINLESS STEEL PER AMS 5640, ALLOY S30300, TYPE 1 OR ASTM A582, TYPE 303, CONDITION A.

PC LEG BODY & CONTACT: BERYLLIUM COPPER PER ASTM B196, ALLOY C17300, TD04.

INSULATOR: PTFE PER ASTM D1710

### FINISHES:

INTERFACE BODY: PASSIVATED PER AMS 2700.

PC LEG BODY: GOLD PER ASTM B488, TYPE II, CODE C, CLASS 1.27 OVER NICKEL PER AMS 26074, CLASS 1, .000050" MIN.

CONTACT: GOLD PER ASTM B488, TYPE II, CODE C, CLASS 1.27 OVER NICKEL PER AMS-QQ-N-290, CLASS 1, .000050" MIN.

### PERFORMANCE:

IMPEDANCE: 50 OHMS

FREQ. RANGE: DC TO 20 GHz

V.S.W.R.: 1.35:1 DC TO 20 GHz

D.W.V.: 500 VRMS

INSULATION RES.: 5,000 MEGOHMS MINIMUM

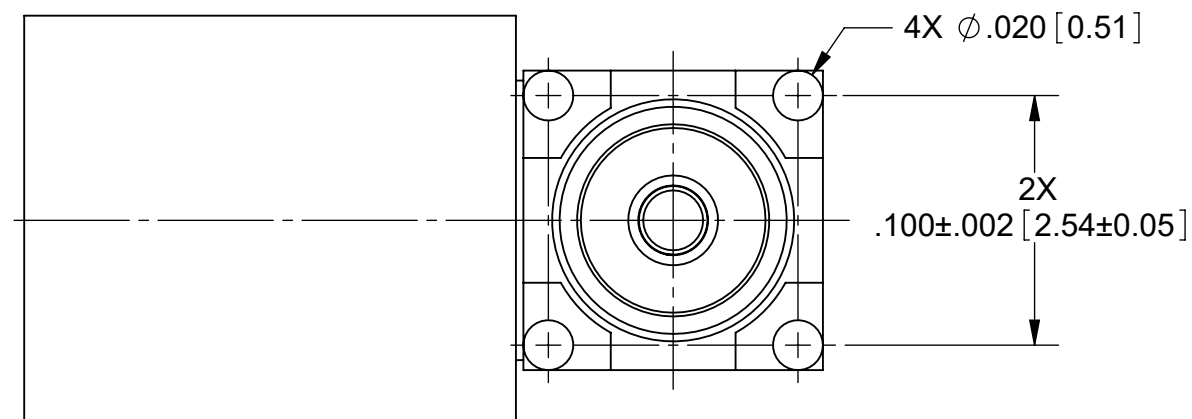

MATERIAL: SEE NOTES	DIMENSIONS ARE IN INCHES TOLERANCES: FRACTIONAL: ±1/64 ANGULAR: X° ±1'0" X'X' ±15'	UNLESS OTHERWISE SPECIFIED 1) ALL DIMENSIONS ARE IN INCHES (MILLIMETERS) 2) ALL DIMENSIONS ARE AFTER PLATING. 3) BREAK CORNERS & EDGES .005 R. MAX. 4) CHAM. 1ST & LAST THREADS. 5) SURFACE ROUGHNESS 63-MIL-STD-10. 6) DIA: 'S ON COMMON CENTERS TO BE CONCENTRIC WITHIN .005 T.I.R. 7) REMOVE ALL BURRS	<b>SV Microwave, Inc.</b> 2400 Centrepark West Drive, Suite 100 West Palm Beach, FL 33409
FINISH: SEE NOTES	DECIMAL: X ±.030 .XX ±.010 .XXX ±.005	INTERPRET DIMENSIONS AND TOLERANCES PER ASME Y14.5M - 1994	TITLE: SMP MALE S.B. R/A PCB MOUNT
SURFACE AREA: N/A	THIRD ANGLE PROJECTION	DRAWN: FED 01/18/11	SIZE: B CAGE CODE: 95077 DWG. NO.: SF1212-6002
PROPRIETARY THE INFORMATION CONTAINED IN THIS DRAWING IS THE SOLE PROPERTY OF SV MICROWAVE, INC. ANY REPRODUCTION IN PART OR AS A WHOLE WITHOUT THE WRITTEN PERMISSION OF SV MICROWAVE, INC IS PROHIBITED.		CHECKED: STW 01/18/11	SCALE: 13:1
		APPROVED: STW 01/18/11	SHEET 1 OF 1