

PRODUCT DATA DRAWING

REVISION HISTORY			
REV	DESCRIPTION	DATE	APPROVED
-	DCN 38106	03/11	PJS
A	REV. DCN 43143	02/27/17	STW

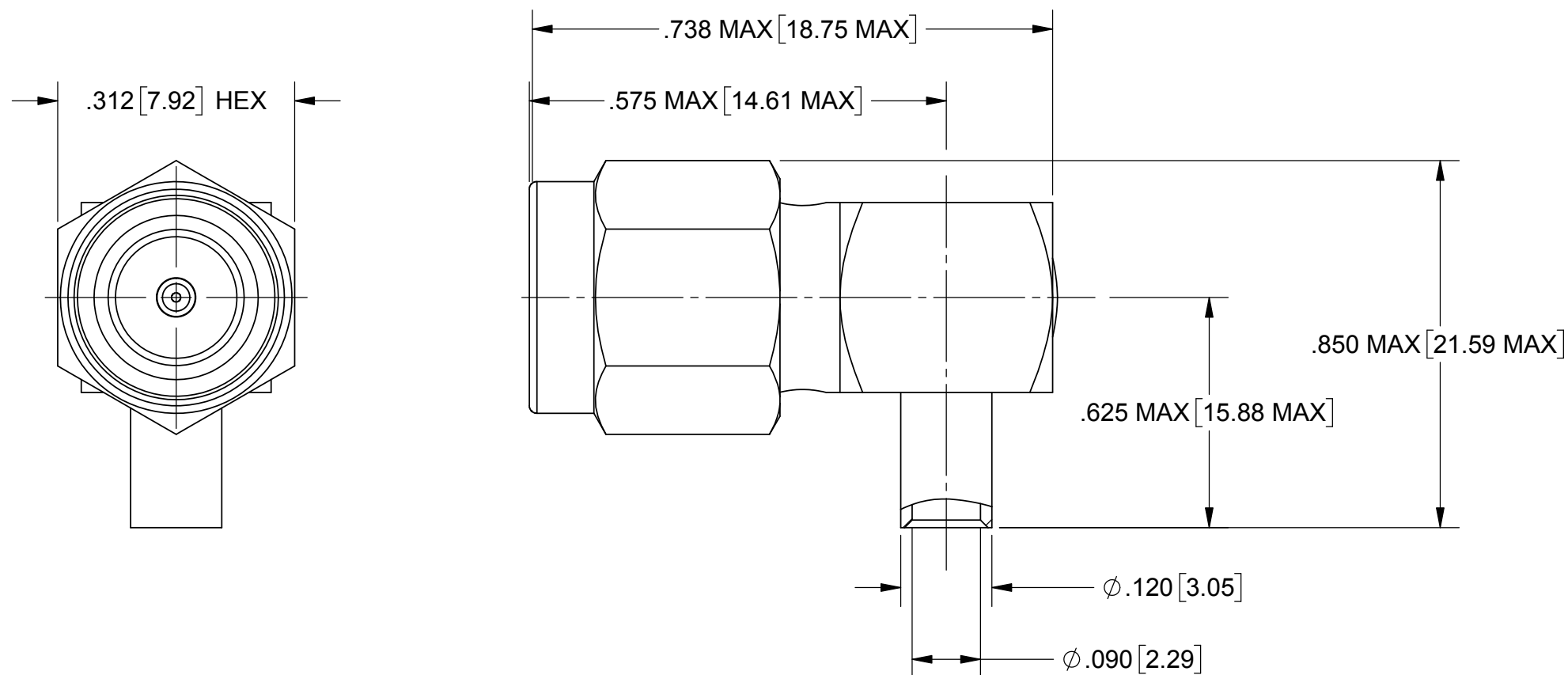

- MATERIAL:**
- BODY & COUPLING NUT:** STAINLESS STEEL PER AMS-5640, ALLOY UNS S30300, TYPE 1 OR ASTM A582, TYPE 303, CONDITION A.
- PRESS CAP:** STAINLESS STEEL PER ASTM A240, ALLOY UNS S30400, TYPE 304.
- CONTACT:** BRASS PER ASTM B16, ALLOY UNS No. C36000.
- LOCK RING:** BERYLLIUM COPPER PER ASTM B196, ALLOY No. UNS C17300, TD04.
- INSULATOR:** PTFE PER ASTM D1710, TYPE I, GRADE 1, CLASS B.
- GASKET:** SILICONE RUBBER PER A-A-59588, CLASS 2B, GRADE 60/70.
- FINISH:**
- COUPLING NUT:** PASSIVATED PER AMS-2700, TYPE 2.
- BODYPRESS CAP & CONTACT:** GOLD PER ASTM B488, TYPE II, CODE C, CLASS 1.27, OVER NICKEL PER AMS-QQ-N-290, CLASS 1, .00005" MIN.

- PERFORMANCE:**
- IMPEDANCE:** 50 OHMS
- FREQ. RANGE:** DC TO 12.4 GHz.
- VSWR:** 1.10+.01F (F IN GHz) OR 80% OF THE UPPER CUTOFF FREQ. OF THE CABLE, WHICHEVER IS LOWER.
- DWV:** 1000 VRMS.
- ISUL. RES.:** 5000 MEGOHMS MINIMUM.

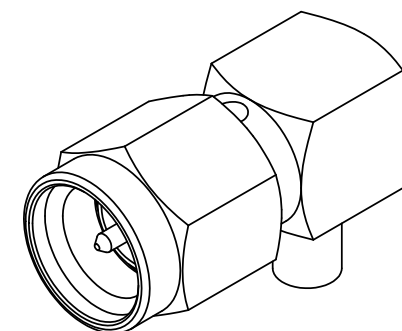

MATERIAL: SEE NOTES	DIMENSIONS ARE IN INCHES TOLERANCES: FRACTIONAL: ±1/64 ANGULAR: X° ±1'0" X"X' ±15'	UNLESS OTHERWISE SPECIFIED 1) ALL DIMENSIONS ARE IN INCHES (MILLIMETERS) 2) ALL DIMENSIONS ARE AFTER PLATING. 3) BREAK CORNERS & EDGES .005 R. MAX. 4) CHAM. 1ST & LAST THREADS. 5) SURFACE ROUGHNESS 63-MIL-STD-10. 6) DIA.'S ON COMMON CENTERS TO BE CONCENTRIC WITHIN .005 T.I.R. 7) REMOVE ALL BURRS	SV Microwave, Inc. 2400 Centrepark West Drive, Suite 100 West Palm Beach, FL 33409
FINISH: SEE NOTES	DECIMAL: X ±.030 .XX ±.010 .XXX ±.005	INTERPRET DIMENSIONS AND TOLERANCES PER ASME Y14.5M - 1994	TITLE: SMA PLUG R/A SOLDER ON FOR .085 SEMI RIGID CABLE
SURFACE AREA: N/A	THIRD ANGLE PROJECTION	DRAWN: PJS 03/29/11	SIZE: B CAGE CODE: 95077 DWG. NO. M39012/80-3107
PROPRIETARY THE INFORMATION CONTAINED IN THIS DRAWING IS THE SOLE PROPERTY OF SV MICROWAVE, INC. ANY REPRODUCTION IN PART OR AS A WHOLE WITHOUT THE WRITTEN PERMISSION OF SV MICROWAVE, INC IS PROHIBITED.		CHECKED: PJS 03/29/11	SCALE: 5:1 SHEET 1 OF 1
		APPROVED: PJS 03/29/11	