

PRODUCT DATA DRAWING

REVISION HISTORY			
REV	DESCRIPTION	DATE	APPROVED
01	PRELIMINARY	09/12	
-	REL. NRN 42505	08/01/18	STW

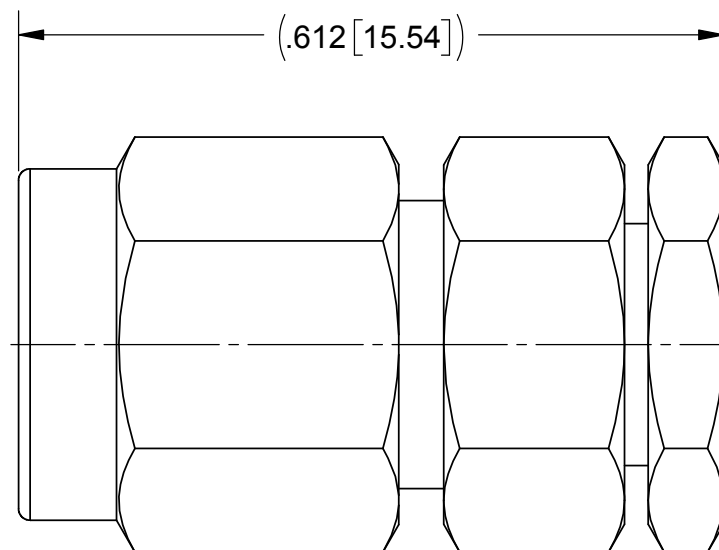
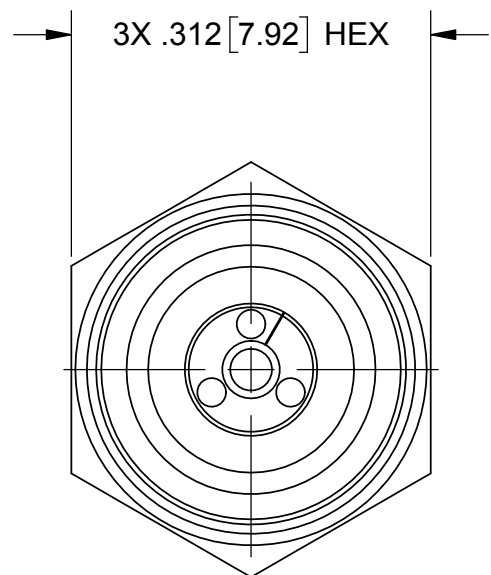

MATERIAL:

BODY, SLEEVE, FERRULE

CLAMP NUT, &
COUPLING NUT:

STAINLESS STEEL PER AMS-5640, ALLOY UNS S30300, TYPE 1
OR ASTM A582, TYPE 303, CONDITION A.

CONTACTS:

BERYLLIUM COPPER PER ASTM B196, ALLOY No. UNS C17300, TD04.

LOCK RING:

BERYLLIUM COPPER PER ASTM B194, B196 OR B197 ALLOY No. UNS C17200 OR C17300.

BEAD:

PEI (ULTEM1000) PER ASTM D 5205.

GASKET:

SILICONE RUBBER PER A-A-59588, CLASS 2B, GRADE 50/60.

FINISH:

BODY, SLEEVE,
CLAMP NUT &
COUPLING NUT:

PASSIVATED PER AMS 2700

FERRULE &
CONTACT:

GOLD PER ASTM B488, TYPE I, CODE C, CLASS 1.27
OVER NICKEL PER AMS-C-26074, CLASS 3, .00005" MIN.

PERFORMANCE:

IMPEDANCE:
FREQ. RANGE:

50 OHMS
DC TO 34.0 GHz

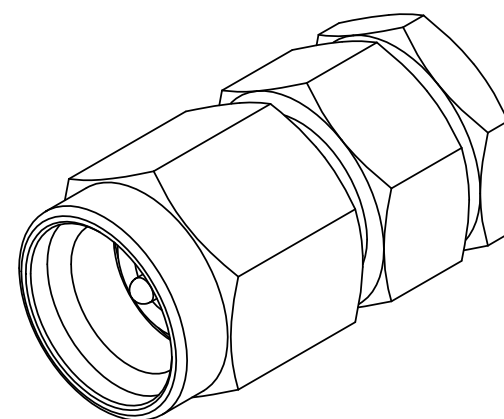

MATERIAL: SEE NOTES	DIMENSIONS ARE IN INCHES TOLERANCES: FRACTIONAL: ±1/64 ANGULAR: X° ±1'0" X°X' ±15'	UNLESS OTHERWISE SPECIFIED 1) ALL DIMENSIONS ARE IN INCHES (MILLIMETERS) 2) ALL DIMENSIONS ARE AFTER PLATING. 3) BREAK CORNERS & EDGES .005 R. MAX. 4) CHAM. 1ST & LAST THREADS. 5) SURFACE ROUGHNESS 63-MIL-STD-10. 6) DIA. 'S ON COMMON CENTERS TO BE CONCENTRIC WITHIN .005 T.I.R. 7) REMOVE ALL BURRS	SV Microwave, Inc. 2400 Centrepark West Drive, Suite 100 West Palm Beach, FL 33409
FINISH: SEE NOTES	DECIMAL: X ±.030 .XX ±.010 .XXX ±.005	INTERPRET DIMENSIONS AND TOLERANCES PER ASME Y14.5M - 1994	TITLE: 2.92mm PLUG FOR UT-141 S.R. CABLE
SURFACE AREA: N/A	THIRD ANGLE PROJECTION	DRAWN: NHR 09/28/12	SIZE: B CAGE CODE: 95077 DWG. NO.: SF1511-60044
PROPRIETARY THE INFORMATION CONTAINED IN THIS DRAWING IS THE SOLE PROPERTY OF SV MICROWAVE, INC. ANY REPRODUCTION IN PART OR AS A WHOLE WITHOUT THE WRITTEN PERMISSION OF SV MICROWAVE, INC IS PROHIBITED.		CHECKED: JMC 07/31/18	SCALE: 6:1
		APPROVED: STW 07/31/18	SHEET 1 OF 1