

# PRODUCT DATA DRAWING

REVISION HISTORY			
REV	DESCRIPTION	DATE	APPROVED
D	DCN 59684	05/26	SEE PDM

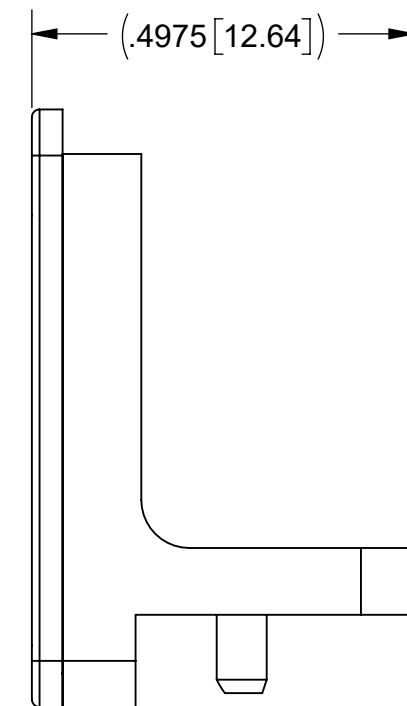
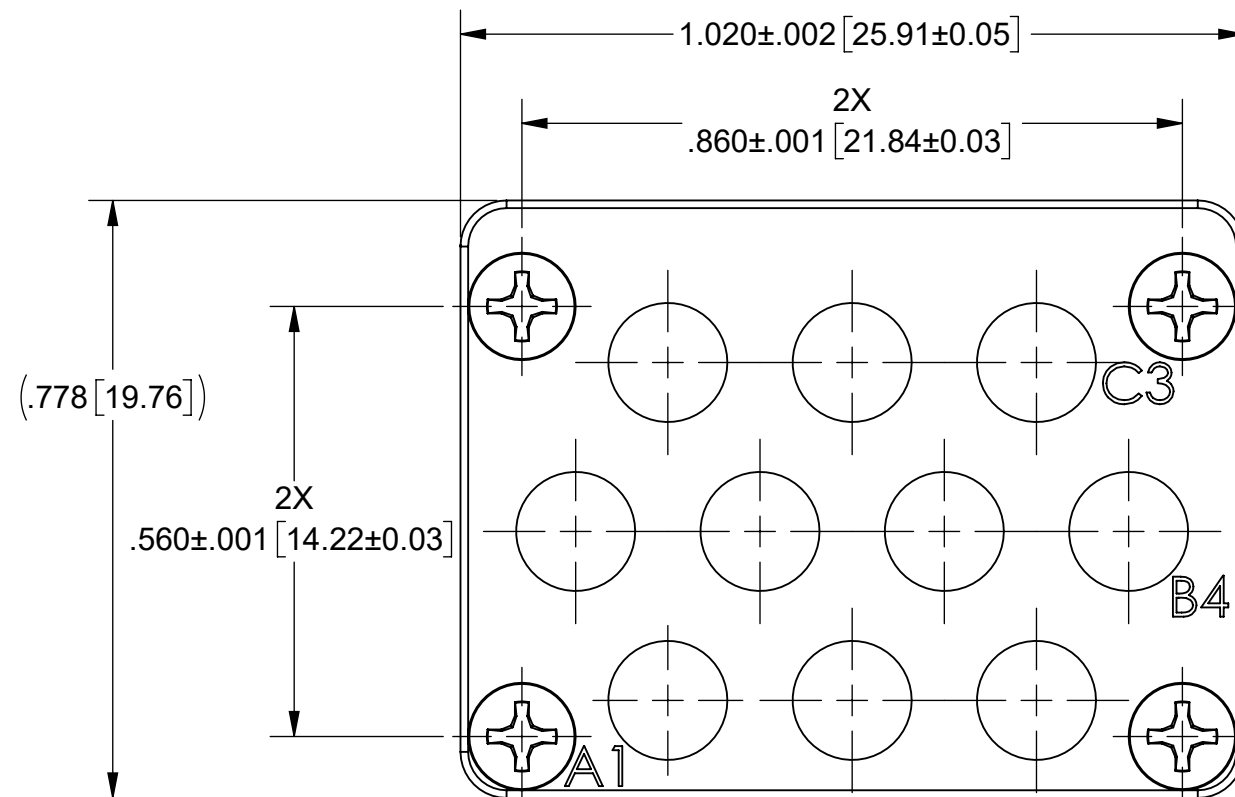
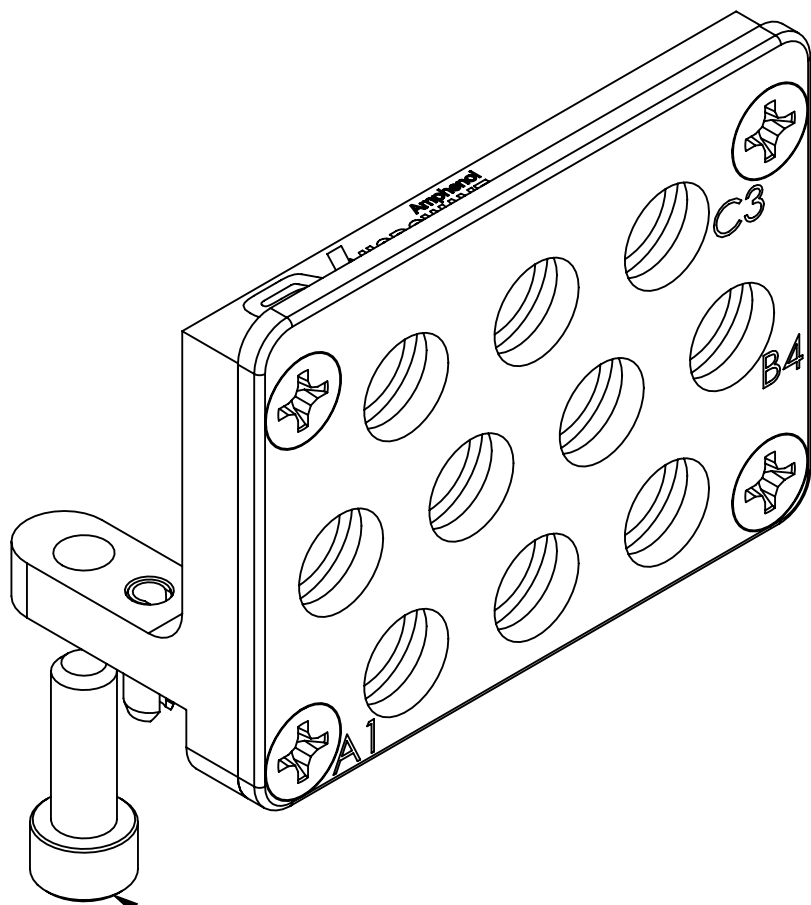

NOTE 5

## MATERIAL:

**BODIES:** STAINLESS STEEL PER AMS-5640, ALLOY UNS S30300, TYPE 1; OR ASTM A582 TYPE 303, COND. A

**SPRING PIN:** 420 STAINLESS STEEL

**SCREWS:** 18-8 STAINLESS STEEL

## FINISH:

**BODIES:** PASSIVATED PER AMS-2700

**SCREWS:** PASSIVATED

## NOTES:

- MATES WITH BACKPLANE MODULE: SF9321-60059.
- POPULATE WITH ADAPTER CONTACT (1132-6116) OR CABLE CONTACTS (Ø.086 3211-60350 & Ø.047 3211-60351).
- REMOVAL TOOL FOR Ø.086 AND Ø.047 CABLE CONTACTS: 500-32-044.
- ADAPTER CONTACT REMOVAL ONLY REQUIRES REMOVAL OF FRONT PLATE PHILIPS HEAD SCREWS.
- DATE CODES 2623 AND LATER INCLUDE THREE SETS OF MOUNTING SCREWS, COVERING PCB THICKNESSES OF .063"-.102", .097"-.133", AND 160"-.196".

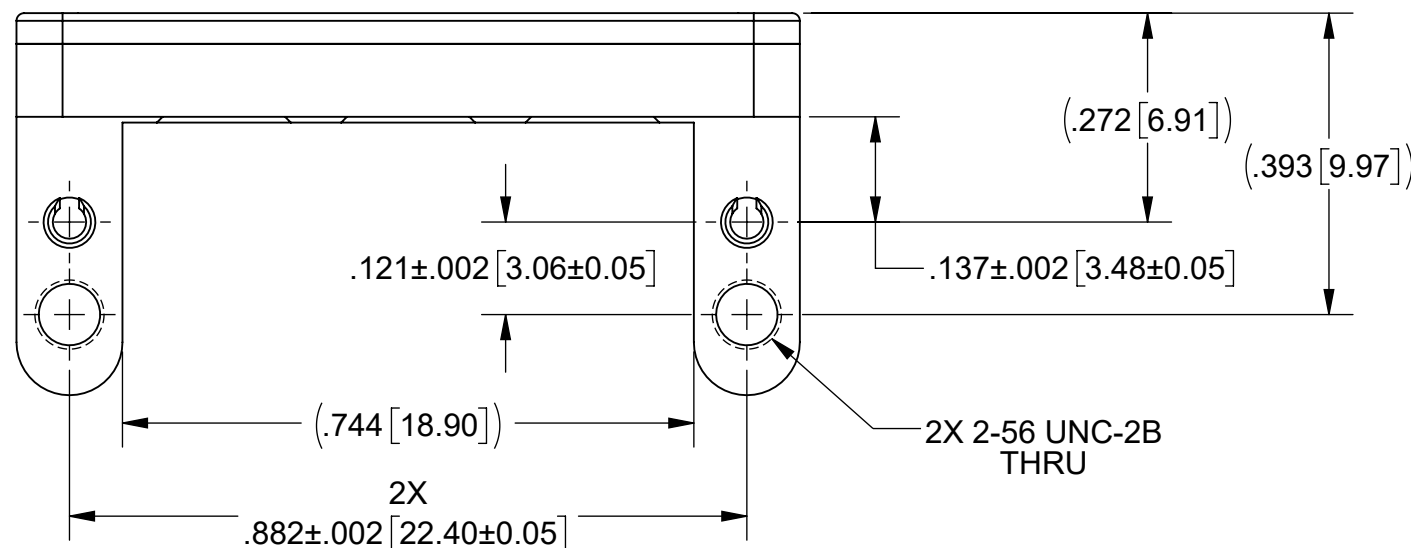

2X 2-56 UNC-2B THRU

MATERIAL: SEE NOTES	DIMENSIONS ARE IN INCHES TOLERANCES: FRACTIONAL: ±1/64 ANGULAR: X° ±1'0" X'X' ±15'	UNLESS OTHERWISE SPECIFIED 1) ALL DIMENSIONS ARE IN INCHES (MILLIMETERS) 2) ALL DIMENSIONS ARE AFTER PLATING. 3) BREAK CORNERS & EDGES .005 R. MAX. 4) CHAM. 1ST & LAST THREADS. 5) SURFACE ROUGHNESS 63-MIL-STD-10. 6) DIA.'S ON COMMON CENTERS TO BE CONCENTRIC WITHIN .005 T.I.R. 7) REMOVE ALL BURRS	 www.svmicrowave.com TITLE: VITA 67.3 PLUG-IN MODULE C, 10 PORT, SMPM
FINISH: SEE NOTES	DECIMAL: X ±.030 .XX ±.010 .XXX ±.005	INTERPRET DIMENSIONS AND TOLERANCES PER ASME Y14.5M - 1994	
SURFACE AREA: N/A	THIRD ANGLE PROJECTION	DRAWN: JPM 03/24/21	SIZE DWG. NO. B 9311-60220
PROPRIETARY THE INFORMATION CONTAINED IN THIS DRAWING IS THE SOLE PROPERTY OF SV MICROWAVE, INC. ANY REPRODUCTION IN PART OR AS A WHOLE WITHOUT THE WRITTEN PERMISSION OF SV MICROWAVE, INC IS PROHIBITED.		CHECKED: SEE PDM	SCALE: 4:1
		APPROVED: SEE PDM	SHEET 1 OF 2

# PRODUCT DATA DRAWING

REVISION HISTORY			
REV	DESCRIPTION	DATE	APPROVED
	SEE SHEET I		SEE PDM

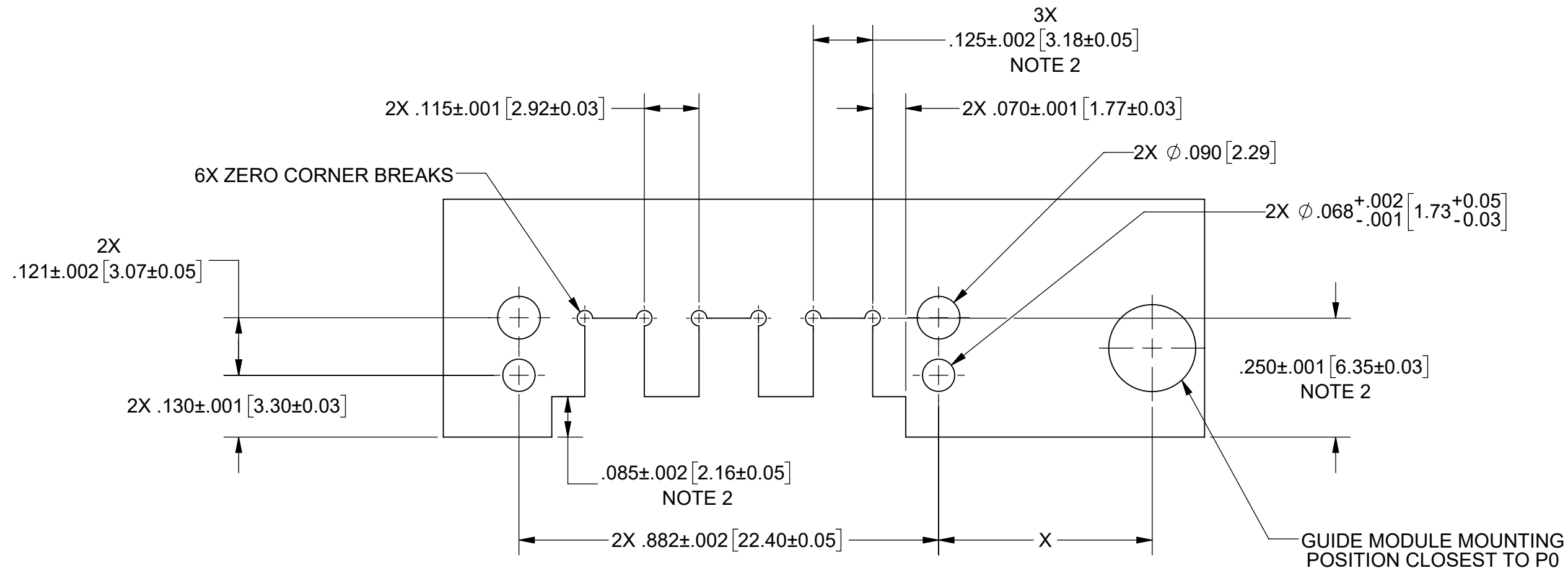

## RECOMMENDED PCB CUTOUT

CONNECTOR LOCATION ON DAUGHTER CARD PCB	
POSITION	DIM 'X'
P2	2.144" [54.46]
P3	3.701" [94.01]
P4	5.035" [127.89]
P5	6.168" [156.67]
P6	7.316" [185.83]

### NOTES:

5. DIMENSIONS WHEN USING 3211-60035 EDGE LAUNCH CONNECTOR.

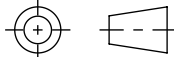
MATERIAL: SEE NOTES	DIMENSIONS ARE IN INCHES TOLERANCES: FRACTIONAL: $\pm 1/64$ ANGULAR: X° $\pm 1'0''$ X'X' $\pm 15'$	UNLESS OTHERWISE SPECIFIED	 www.svmicrowave.com	
FINISH: SEE NOTES	DECIMAL: X $\pm .030$ .XX $\pm .010$ .XXX $\pm .005$	1) ALL DIMENSIONS ARE IN INCHES (MILLIMETERS) 2) ALL DIMENSIONS ARE AFTER PLATING. 3) BREAK CORNERS & EDGES .005 R. MAX. 4) CHAM. 1ST & LAST THREADS. 5) SURFACE ROUGHNESS 63-MIL-STD-10. 6) DIA.'S ON COMMON CENTERS TO BE CONCENTRIC WITHIN .004 T.I.R. 7) REMOVE ALL BURRS		TITLE: VITA 67.3 PLUG-IN MODULE C, 10 PORT, SMPM
SURFACE AREA: N/A	INTERPRET DIMENSIONS AND TOLERANCES PER ASME Y14.5M - 1994	THIRD ANGLE PROJECTION	DRAWN: JPM 03/24/21 CHECKED: SEE PDM APPROVED: SEE PDM	SIZE DWG. NO. <b>B</b> 9311-60220
<b>PROPRIETARY</b> THE INFORMATION CONTAINED IN THIS DRAWING IS THE SOLE PROPERTY OF SV MICROWAVE, INC. ANY REPRODUCTION IN PART OR AS A WHOLE WITHOUT THE WRITTEN PERMISSION OF SV MICROWAVE, INC IS PROHIBITED.		SCALE: 4:1	SHEET 2 OF 2	