

PRODUCT DATA DRAWING

REVISION HISTORY			
REV	DESCRIPTION	DATE	APPROVED
A	55097	8/24	SEE PDM

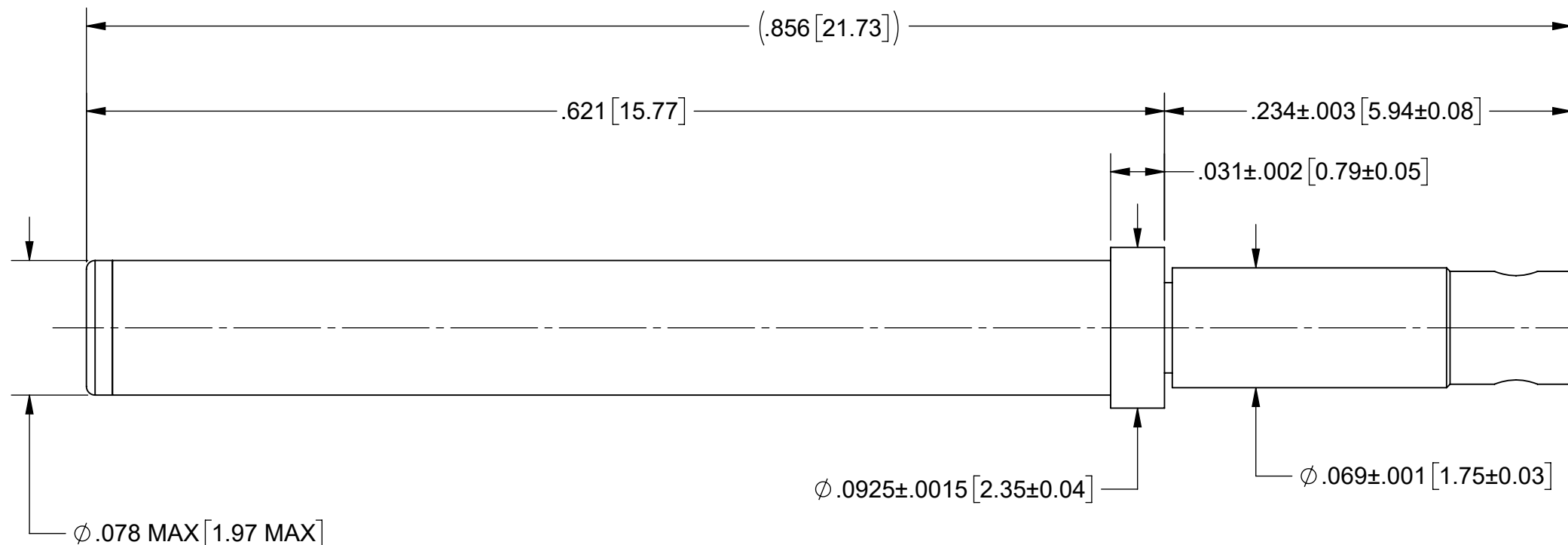
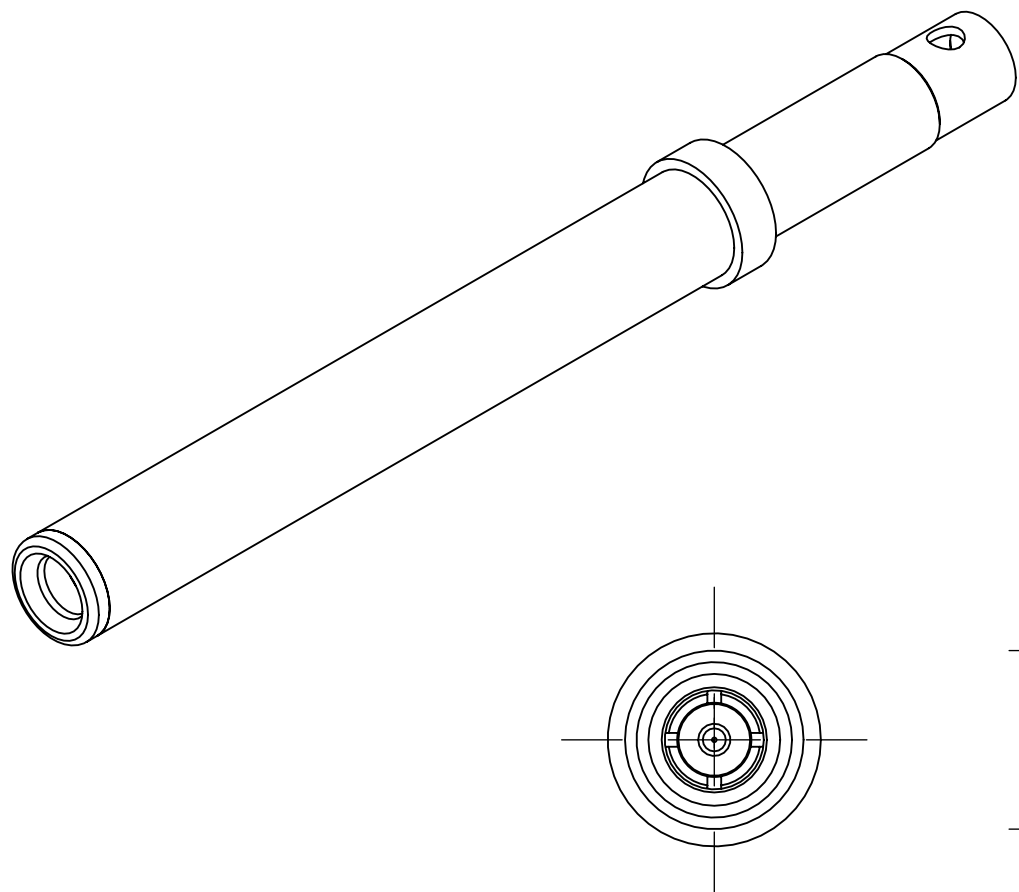

MATERIAL:

SLEEVE & SHROUD: STAINLESS STEEL PER AMS 5640, ALLOY UNS S30300, TYPE 1 OR ASTM A582 TYPE 303, CONDITION A.

BODIES, FERRULE, & CONTACT: BERYLLIUM COPPER PER ASTM B196, ALLOY No. UNS C17300, TD04.

INSULATOR: PTFE PER ASTM D1710, TYPE I, GRADE 1, CLASS B.

BEAD: ULTEM 1000 PER ASTM D5205

SPRING: MUSIC WIRE

FINISH:

SLEEVE & SHROUD: PASSIVATED PER AMS 2700

BODIES, FERRULE, & CONTACT: GOLD PER ASTM B488, TYPE II, CODE C, CLASS 1.27, OVER NICKEL PER AMS-QQ-N-290, CLASS 1, .00005" MIN.

SPRING: ZINC PER ASTM B633, TYPE III

PERFORMANCE:

IMPEDANCE: 50 OHMS
FREQ. RANGE: DC TO 40.0 GHz.

NOTES:

- DESIGNED FOR USE IN SERIES I, III, & IV D38999 CIRCULAR CONNECTORS.
- MATES TO 2041-40001.

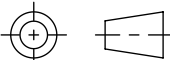
MATERIAL: SEE NOTES	DIMENSIONS ARE IN INCHES TOLERANCES: FRACTIONAL: $\pm 1/64$ ANGULAR: X° $\pm 1'0''$ X'X' $\pm 15'$	UNLESS OTHERWISE SPECIFIED 1) ALL DIMENSIONS ARE IN INCHES (MILLIMETERS) 2) ALL DIMENSIONS ARE AFTER PLATING. 3) BREAK CORNERS & EDGES .005 R. MAX. 4) CHAM. 1ST & LAST THREADS. 5) SURFACE ROUGHNESS 63-MIL-STD-10. 6) DIA: 'S ON COMMON CENTERS TO BE CONCENTRIC WITHIN .005 T.I.R. 7) REMOVE ALL BURRS	 www.svmicrowave.com TITLE: SV20 SIZE 20 SOCKET CONTACT FOR .047 CABLE
FINISH: SEE NOTES	DECIMAL: X $\pm .030$.XX $\pm .010$.XXX $\pm .005$	INTERPRET DIMENSIONS AND TOLERANCES PER ASME Y14.5M - 1994	
SURFACE AREA: N/A	THIRD ANGLE PROJECTION	DRAWN: JPM 8/26/24	SIZE DWG. NO. 2051-60001
PROPRIETARY THE INFORMATION CONTAINED IN THIS DRAWING IS THE SOLE PROPERTY OF SV MICROWAVE, INC. ANY REPRODUCTION IN PART OR AS A WHOLE WITHOUT THE WRITTEN PERMISSION OF SV MICROWAVE, INC IS PROHIBITED.		CHECKED: SEE PDM	SCALE: 12:1
		APPROVED: SEE PDM	SHEET 1 OF 1