

PRODUCT DATA DRAWING

REVISION HISTORY			
REV	DESCRIPTION	DATE	APPROVED
A	DCN 53954	03/24	SEE PDM

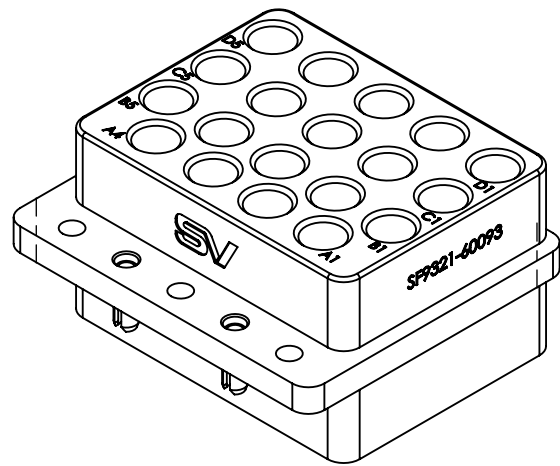

HOLE CHART		
HOLE No.	X	Y
ORIGIN	0.000	0.000
A1	0.508	0.217
A2	0.303	0.217
A3	0.103	0.217
A4	-0.108	0.217
B1	0.610	0.365
B2	0.405	0.365
B3	0.200	0.365
B4	-0.005	0.365
B5	-0.210	0.365
C1	0.610	0.557
C2	0.405	0.557
C3	0.200	0.557
C4	-0.005	0.557
C5	-0.210	0.557
D1	0.610	0.749
D2	0.405	0.749
D3	0.200	0.749
D4	-0.005	0.749
D5	-0.210	0.749

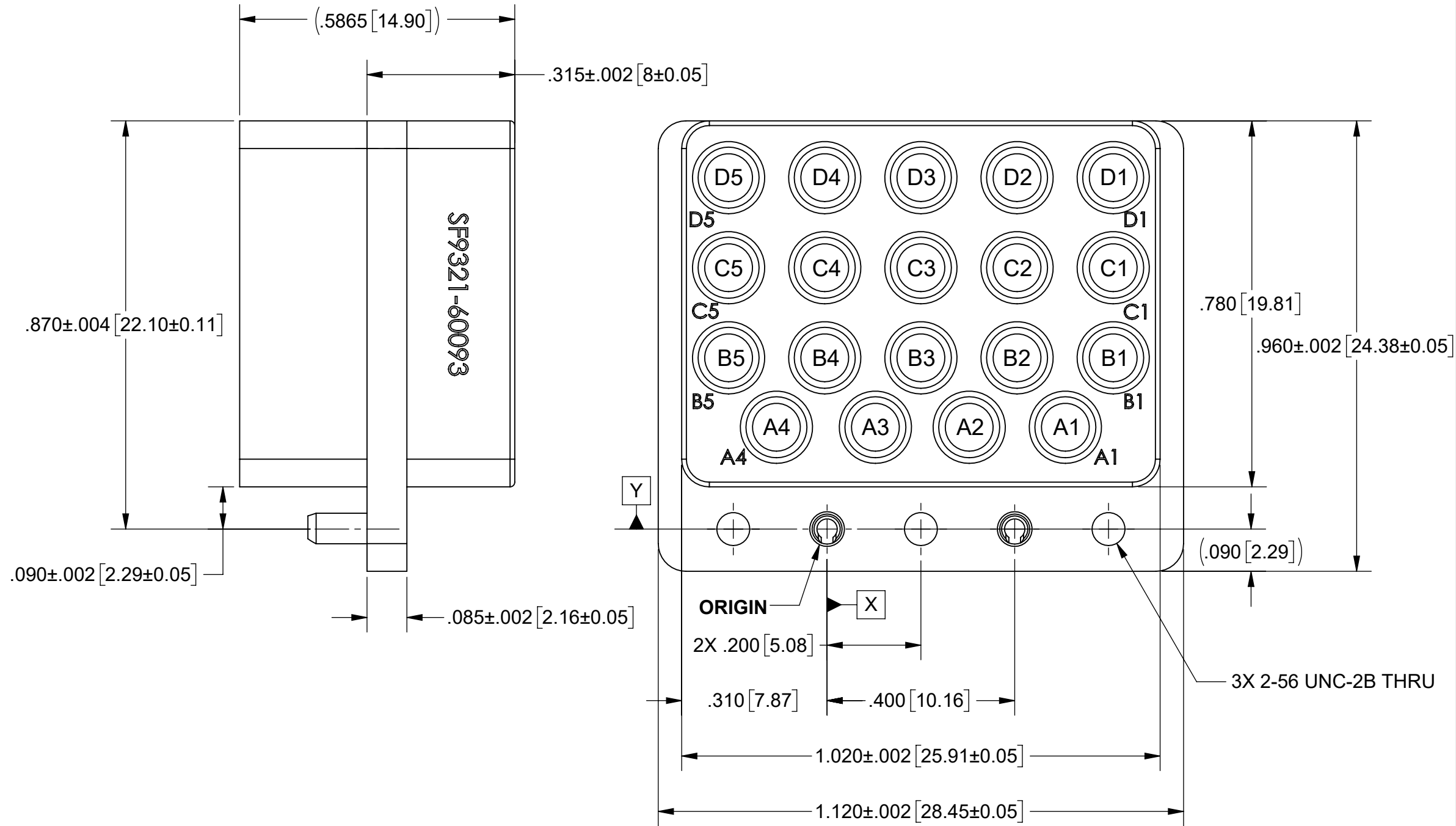

MATERIAL:

BODY: STAINLESS STEEL PER AMS-5640, ALLOY UNS S30300, TYPE 1; OR ASTM A582 TYPE 303, COND. A

SPRING PINS: 420 STAINLESS STEEL

FINISH:

BODY: PASSIVATED PER AMS-2700

NOTES:

1. USES CONTACT 3821-40024 OR SIMILAR.
2. DESIGNED FOR USE WITH SF9311-60171

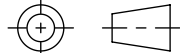
MATERIAL: SEE NOTES	DIMENSIONS ARE IN INCHES TOLERANCES: FRACTIONAL: ±1/64 ANGULAR: X° ±1'0" X'X' ±15'	UNLESS OTHERWISE SPECIFIED 1) ALL DIMENSIONS ARE IN INCHES (MILLIMETERS) 2) ALL DIMENSIONS ARE AFTER PLATING. 3) BREAK CORNERS & EDGES .005 R. MAX. 4) CHAM. 1ST & LAST THREADS. 5) SURFACE ROUGHNESS 63-MIL-STD-10. 6) DIA: 'S ON COMMON CENTERS TO BE CONCENTRIC WITHIN .005 T.I.R. 7) REMOVE ALL BURRS	 <p>Amphenol www.svmicrowave.com</p>
FINISH: SEE NOTES	DECIMAL: X ±.030 .XX ±.010 .XXX ±.005	INTERPRET DIMENSIONS AND TOLERANCES PER ASME Y14.5M - 1994	
SURFACE AREA: N/A	THIRD ANGLE PROJECTION	DRAWN: SJ 05/24/19	TITLE: VITA 67.3 BACKPLANE MODULE C, 19 PORT, SMPS
<p>PROPRIETARY</p> <p>THE INFORMATION CONTAINED IN THIS DRAWING IS THE SOLE PROPERTY OF SV MICROWAVE, INC. ANY REPRODUCTION IN PART OR AS A WHOLE WITHOUT THE WRITTEN PERMISSION OF SV MICROWAVE, INC IS PROHIBITED.</p>		CHECKED: SEE PDM	SIZE DWG. NO. B SF9321-60093
		APPROVED: SEE PDM	SCALE: 4:1 SHEET 1 OF 2

REVISION HISTORY			
REV	DESCRIPTION	DATE	APPROVED
	SEE SHEET 1		SEE PDM

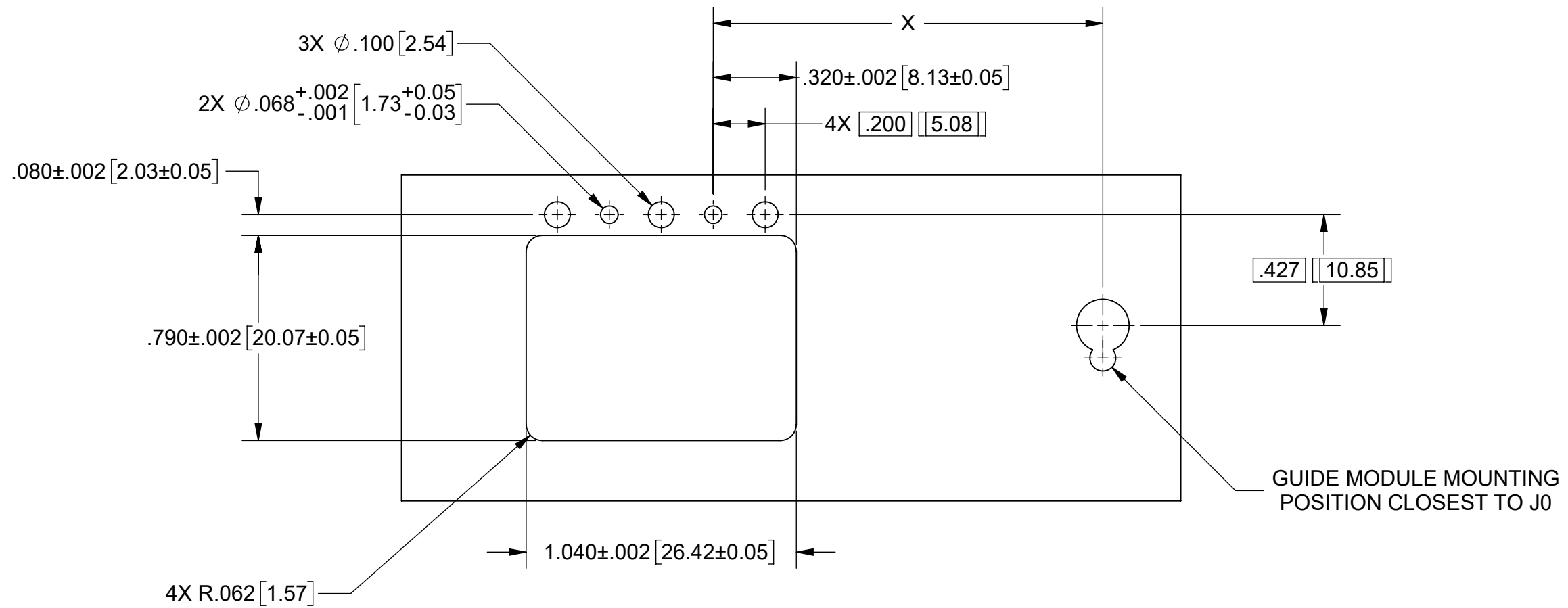

RECOMMENDED PCB CUTOUT

CONNECTOR LOCATION ON BACKPLANE PCB	
POSITION	DIM 'X'
J2	2.385" [60.58]
J3	3.942" [100.13]
J4	5.276" [134.00]
J5	6.409" [162.80]
J6	7.557" [191.95]

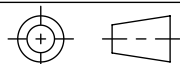
MATERIAL: SEE NOTES	DIMENSIONS ARE IN INCHES TOLERANCES: FRACTIONAL: ±1/64 ANGULAR: X° ±1'0" X'X' ±15'	UNLESS OTHERWISE SPECIFIED 1) ALL DIMENSIONS ARE IN INCHES (MILLIMETERS) 2) ALL DIMENSIONS ARE AFTER PLATING. 3) BREAK CORNERS & EDGES .005 R. MAX. 4) CHAM. 1ST & LAST THREADS. 5) SURFACE ROUGHNESS 63-MIL-STD-10. 6) DIA: 'S ON COMMON CENTERS TO BE CONCENTRIC WITHIN .004 T.I.R. 7) REMOVE ALL BURRS	 Amphenol SV MICROWAVE www.svmicrowave.com
FINISH: SEE NOTES	DECIMAL: X ±.030 .XX ±.010 .XXX ±.005	INTERPRET DIMENSIONS AND TOLERANCES PER ASME Y14.5M - 1994	
SURFACE AREA: N/A	THIRD ANGLE PROJECTION	DRAWN: SEE SHEET 1	TITLE: VITA 67.3 BACKPLANE MODULE C, 19 PORT, SMPS
PROPRIETARY THE INFORMATION CONTAINED IN THIS DRAWING IS THE SOLE PROPERTY OF SV MICROWAVE, INC. ANY REPRODUCTION IN PART OR AS A WHOLE WITHOUT THE WRITTEN PERMISSION OF SV MICROWAVE, INC IS PROHIBITED.		CHECKED: SEE PDM	SIZE DWG. NO. B SF9321-60093
		APPROVED: SEE PDM	SCALE: 4:1 SHEET 2 OF 2