

PRODUCT DATA DRAWING

REVISION HISTORY			
REV	DESCRIPTION	DATE	APPROVED
A	DCN 41768	10/15	SEE PDM
B	DCN 53688	01/24	

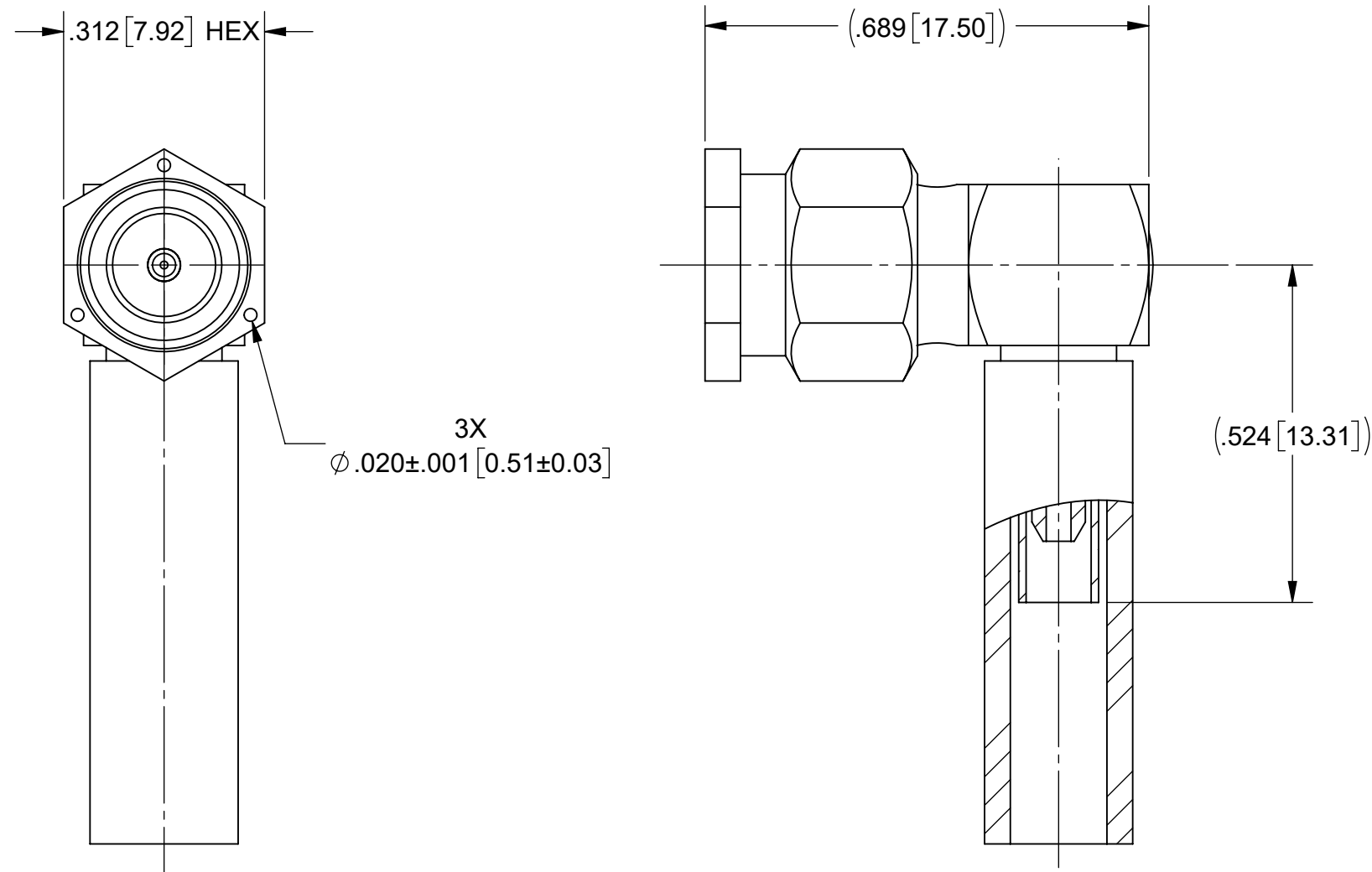
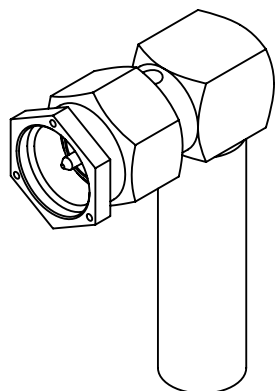

MATERIAL:

BODY, FERRULE, & COUPLING NUT:

STAINLESS STEEL PER AMS-5640, ALLOY UNS S30300, TYPE 1

CONTACT & CRIMP RING:

BRASS PER ASTM B16, ALLOY UNS No. C36000

LOCK RING

BERYLLIUM COPPER PER ASTM B196, ALLOY No. UNS C17300, TD04

CAP:

STAINLESS STEEL PER ASTM A240, UNS S30400

INSULATOR:

PTFE PER ASTM D1710, TYPE I, GRADE 1, CLASS B

GASKET:

SILICONE RUBBER PER A-A-59588, CLASS 2B, GRADE 50/60

TUBING:

M23053/4

FINISH:

BODY, FERRULE CAP & CRIMP RING:

GOLD PER MIL-DTL-45204, TYPE II, GRADE C, CLASS 1, OVER NICKEL PER AMS-QQ-N-290, CLASS 1 (.0002 MIN).

CONTACT:

GOLD PER ASTM B488, TYPE II, CODE C, CLASS 1.27, OVER NICKEL PER AMS-QQ-N-290, CLASS 1, .00005" MIN.

COUPLING NUT:

PASSIVATED PER AMS-2700

PERFORMANCE:

IMPEDANCE: 50 OHMS
 FREQ. RANGE: DC TO 12.4 GHz
 VSWR: 1.20 + .03(F):1 DC TO 12.4 GHz
 INSERTION LOSS: .15 X SQRT(F(F IN GHz))

MATERIAL: SEE NOTES	DIMENSIONS ARE IN INCHES TOLERANCES: FRACTIONAL: ±1/64 ANGULAR: X° ±1'0" X'X' ±15'	UNLESS OTHERWISE SPECIFIED 1) ALL DIMENSIONS ARE IN INCHES (MILLIMETERS) 2) ALL DIMENSIONS ARE AFTER PLATING. 3) BREAK CORNERS & EDGES .005 R. MAX. 4) CHAM. 1ST & LAST THREADS. 5) SURFACE ROUGHNESS 63-MIL-STD-10. 6) DIA.'S ON COMMON CENTERS TO BE CONCENTRIC WITHIN .005 T.I.R. 7) REMOVE ALL BURRS	 Amphenol www.svmicrowave.com TITLE: SMA MALE R/A FOR RG178, 196 CABLE
FINISH: SEE NOTES	DECIMAL: X ±.030 .XX ±.010 .XXX ±.005	INTERPRET DIMENSIONS AND TOLERANCES PER ASME Y14.5M - 1994	
SURFACE AREA: N/A	THIRD ANGLE PROJECTION	DRAWN: DAL 10/13/15	SIZE DWG. NO. M39012/56-3006
PROPRIETARY THE INFORMATION CONTAINED IN THIS DRAWING IS THE SOLE PROPERTY OF SV MICROWAVE, INC. ANY REPRODUCTION IN PART OR AS A WHOLE WITHOUT THE WRITTEN PERMISSION OF SV MICROWAVE, INC IS PROHIBITED.		CHECKED: SEE PDM	SCALE: 4:1
		APPROVED: SEE PDM	SHEET 1 OF 1